







APPLICATION AND DATA SHEETS

CMW Copper Base Alloys	4
ELKONITE®, ELKON®, ANVILOY® Materials	5
Metric Conversions Inches to Millimeter	6
Taper Dimensions	7
CMW and RWMA Straight Electrode coding	7
Holder and Electrode application sketches	28
Multispot Pressure Equalizing Holder Set-ups	41
Welding Bar and Rod Stock	48
ELKONITE® Bar Stock	49
GCAP® Weld and Stepper Schedule	51
Spot Welding Schedules for Low Carbon Steel	52
Projection Welding Schedules for Low Carbon Steel	53
Welding Schedules for Stainless Steel	54
Welding Schedules for Galvanized Low Carbon Steel	55
Recommended Electrode Materials	56
Resistance Welding Electrode Maintenance	57
Welding Electrode Evaluation Form	58
Graph Facsimile	59
Do's and Don'ts for Resistance Welding Electrodes	60

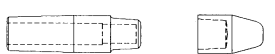
CAP ELECTRODES, GCAPS®, AND SHANKS

	Cap Electrodes	8
	GCAP® Electrodes	9
	Cap Shanks	10, 11

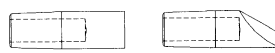
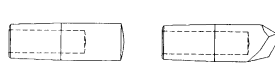

STRAIGHT ELECTRODES

	Dome and Pointed Nose	12
	Flat and Offset Nose	13
	Truncated, Radius, and 30° Nose	14
	Elkon® & Elkonite® Faced Nose	14

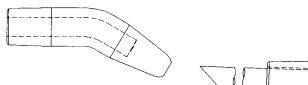
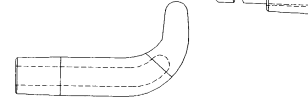

BENT ELECTRODES

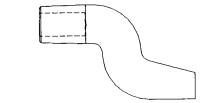
	Single and Radius Bend	15
	Double Bend	16,17

IRREGULAR ELECTRODES

	Crank	18
	Spade	19
	Gun	19

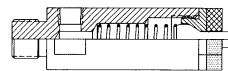
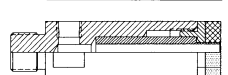
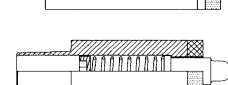
STUD AND NUT ELECTRODES

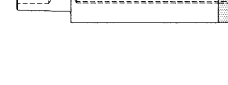
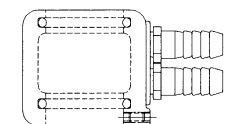
	Chameleon/Max-Life™ Nut Electrodes	20
	Chameleon/Max-Life™ Stud Electrodes	21
	Self-Piloting Nut Electrodes	22
	Non Piloting Nut Electrodes	23
	Stud or Pin Electrodes	24
	Cooling Jackets for Stud and Nut Electrodes	24

BACK-UP ELECTRODES

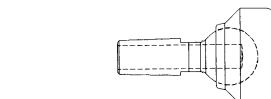
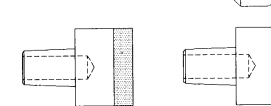
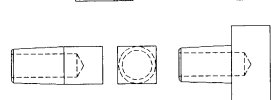
	Swivel Head	25
	Large Round Head CMW® 3 and ELKONITE® FACED	25
	Square and Rectangular Head	25

SOCKET OR BUTTON ELECTRODES

		37
--	--	----

"NU-TWIST"® ELECTRODES

		37
--	--	----

THREADED ELECTRODES



26

HOLDER TO ELECTRODE ADAPTERS



Non Ejector

27



Ejector

30

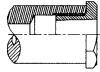

Assembly

Examples 29,30,31,33

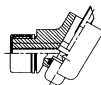

Universal 35

ELECTRODE HOLDERS

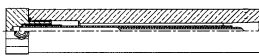

100 Series Straight
Non Ejector

29

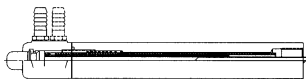

200 Series Straight
Ejector

30

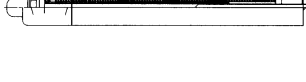

300 Series
Premium Straight
Ejector

31

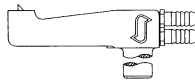

400 Series
Light Non-Ejector
Offset

32

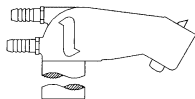

500 Series
Heavy Duty Ejector
Offset

33

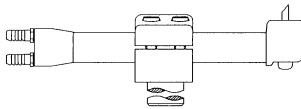

600 Series Universal
Holders

34

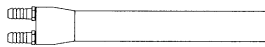

600 Series
Universal Holder
Components

35

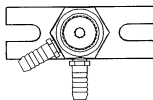

Platen Mounted
Holders

43

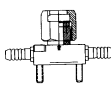

800 Series
"Nu-Twist"[®]
Surface and
Threaded Adapters

36

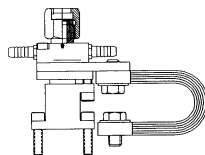

Hydraulic Equalizing
Adapters for
800 Series

38

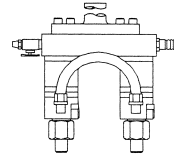

Dual Mounted
Hydraulic
"Nu-Twist"[®]
Assemblies

39

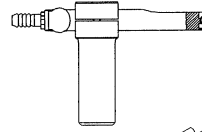

900 Series Light
Universal Holders
for Socket
Electrodes

42

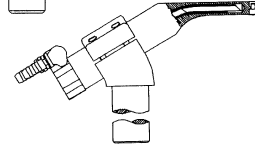

950 Series Paddle
Holders for Socket
Electrodes 42

LOW INERTIA HOLDERS

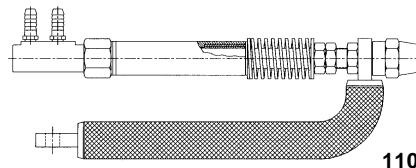

1100 Series
Adjust-A-Pressure
Low Inertia Holders 40

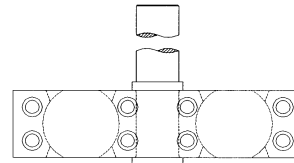

1150 Series
Adjust-A-Pressure
Adapters 40

MULTISPOT ADAPTERS FOR AIR OR HYDRAULIC PISTONS

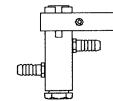

1200 Series
Multi-Spot Adapters 44

CONTACTORS



Welder Contactors 44

ACCESSORIES

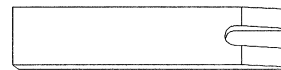

Cap Electrode
Extractor Fork 45



Reamers, Hose
Connectors, and
Hose Clamps 45

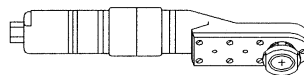

Pneumatic
Electrode Dresser
and Cutters 46,47



Hand Electrode
Dressers 47



Force Gauge 50

COPPER BASE ALLOYS



NSRW Co., Inc. (800) 933-6779, FAX: (205) 663-3221 Authorized Distributor CMW Inc.

Long electrode life is of paramount importance to the user of resistance welding equipment. Selection of the proper CMW alloy or combination of alloys will help to give improved weld strength and electrode life.

CMW electrodes are fabricated from alloys selected from the results of laboratory and practical field tests. For special problems, CMW engineers will make recommendations based on their years of experience.

Typical Physical and Mechanical Properties of CMW® Copper Based Alloys

CMW ALLOY	Condition	Principal Elements	Class #	R.W.M.A. Alloy Number	Hardness Rockwell	Electrical Conductivity %I.A.C.S.	Ultimate Tensile Strength, psi	Elongation % in 2"	Permanent Softening Begins at	
									°C	°F
CMW® 28	Wrought**	Copper, Zirconium	1	1.15000	70 B	90	66,000	10	500	930
	Cast									
CMW® 3	Wrought***	Copper, Chromium	2	2.18200	83 B	85	75,000	15	500	930
	Wrought***									
CMW® 328	Wrought***	Copper, Chromium, Zirconium	2	2.18150	83 B	85	75,000	15	500	930
CMW® 353	Wrought	Copper, Nickel, Silicon, Chromium	3	3.18000	94 B	48	100,000	13	455	850
	Cast									
CMW® 100	Wrought	Copper, Nickel, Beryllium	3	3.17510	100 B	48	110,000	10	455	850
	Cast									
CMW® 73	Wrought	Copper, Beryllium	4	4.17200	38 C	23	170,000	4	375	710
ELKALOY® D	Cast	Copper, Aluminum	5	5.95300	92 B	13	85,000	15	620	1150
Copper	Cast	Pure Copper		—	30 B	95	25,000	50	200	390
	Wrought									
CMW® DSC	Wrought	Copper, Al ₂ O ₃	20	—	75 B	85	54,000	25	800	1475

Note: All properties shown are TYPICAL and should not be used for specifications
 * Cold drawn bars up to 1" diameter
 ** Cold drawn bars up to 5/8" diameter
 *** Heat treated and cold drawn bars up to 1" diameter

TYPICAL USAGE

CMW® 28 material is recommended for spot welding of coated steels and high conductivity materials, excluding copper and silver.

CMW® 3 material is recommended for spot and seam welding cold and hot-rolled steels and coated materials as well as current carrying shafts and arms, back-up bars for both resistance and arc welding and electrical current carrying structural parts and springs.

CMW® 328 material is recommended for spot and seam welding cold and hot rolled steels. There is some evidence that CMW® 328 outperforms CMW® 3 material when welding coated or galvanized steels.

CMW® 353 material is recommended for heavy duty offset holders, back-up bars, flash welding dies, current carrying structural members, shafts and bushings in combination with CMW® 3.

CMW® 100 material is recommended for spot and seam welding stainless steel and high temperature heat resisting alloys requiring high weld forces, flash welding dies, back-up bars, projection welding electrodes, and high strength, high conductivity electrical components and springs.

CMW® 73 material is recommended for flash welding dies, springs, electrical components, high strength back-ing material for brazed assemblies and wire guides.

ELKALOY® D material is recommended for butt and flash welding dies and clamps for cold rolled and stainless steel, current carrying structural parts, jigs and fixtures, pickling racks and baskets.

CMW® DSC material has exceptional resistance to deformation when welding, and is highly recommended as welding caps for welding coated and galvanized steels. It allows a stable start-up, and generally outlasts other cap materials when welding parameters are not carefully controlled. The material requires upset cold work to develop its properties, and is therefore only available as caps or cap blanks.

NSRW Co., Inc. (800) 933-6779, FAX: (205) 663-3221 Authorized Distributor CMW Inc.

ELKONITE® is the registered trade mark of CMW used to identify a group of metal compositions whose elements consist basically of the refractory metals tungsten, molybdenum and tungsten carbide combined with copper. Combinations of these elements produce dense, hard metals of superior wear resistance and strength at elevated temperatures, coupled with good thermal and electrical conductivity. The mechanical and physical properties of the ELKONITE® materials make them particularly suitable as the die inserts and facings for volume projection welding, flash and butt welding,

electrical upsetting, electroforging and mash welding applications.

ELKONITE® material is also used successfully as facing on spot welding electrodes where heat balance or mechanical wear resistance are required. The initial premium cost of ELKONITE® material is offset by lower production cost per weld due to long die life and less electrode dressing time. The high stability of ELKONITE® material insures uniform heating and prevents misalignment, resulting in a higher quality weld.

Typical Physical and Mechanical Properties of CMW® Refractory Based Materials

CMW GRADE	Type of Material	Class #	R.W.M.A. Group B Material	Hardness Rockwell	Electrical Conductivity %I.A.C.S.	Ultimate Tensile Strength, psi	Cross Breaking Strength psi
ELKONITE® 1W3	Tungsten-Copper	10	10.74450	77 B	53	63,000	110,000
ELKONITE® 3W3	Tungsten-Copper		—	90 B	50	75,000	130,000
ELKONITE® 5W3	Tungsten-Copper		—	95 B	48	85,000	140,000
ELKONITE® 10W3	Tungsten-Copper	11	11.74400	98 B	45	90,000	150,000
ELKONITE® 30W3	Tungsten-Copper	12	12.74350	103 B	41	98,000	170,000
ELKONITE® 3W53	Tungsten-Copper Alloy		—	105 B	30	120,000	180,000
ELKONITE® 10W53*	Tungsten-Copper Alloy		—	109 B	28	160,000	200,000
ELKONITE® TC5	Tungsten Carbide-Copper		—	94 B	45	70,000	140,000
ELKONITE® TC10	Tungsten Carbide-Copper		—	100 B	42	75,000	160,000
ELKONITE® TC20	Tungsten Carbide-Copper		—	37 C	30	85,000	180,000
ELKONITE® TC53*	Tungsten Carbide-Copper Alloy		—	47 C	18	150,000	220,000
ELKON® 100W	Tungsten	13	13.74300	39 C	30	150,000	200,000
ELKON® 100M	Molybdenum	14	14.42300	90 B	30	80,000	120,000
ANVILOY® 1150**	Tungsten-Nickel-Iron-Molybdenum		—	34 C	13	140,000	280,000

Note: All properties shown are TYPICAL and should not be used for specifications
 * Properties are in fully heat treated condition
 ** Hardness is 56 HRA at 1475 °F (800°C)

TYPICAL USES

ELKONITE® 1W3 and 3W3 alloys are generally used for flash and butt welding die inserts where higher electrical and thermal conductivity is necessary and where a degree of malleability is desirable. These materials are also used for spot welding (as a radius faced electrode) low conductivity ferrous metals such as stainless steel.

ELKONITE® 5W3 and TC5 alloys are normally used for light duty projection welding dies where welding pressures are not extreme.

ELKONITE® 10W3 alloy is used for electrode and die inserts in most flash and butt welding dies and for projection welding dies where welding pressures are moderate. It is also used for light electrical upsetting, electroforging dies and seam welder bushing inserts.

ELKONITE® 30W3 and TC10 alloys are recommended for volume projection welding dies where the pressures involved are relatively high. Electrical upsetting of non-ferrous metals and low carbon steel is usually accomplished by the use of such ELKONITE® materials as die facings. Cross-wire welding of large, diameter wire and rod is accomplished with such ELKONITE® materials.

ELKONITE® 3W53 and 10W53 are heat treatable grades of ELKONITE® materials supplied in the fully heat treated condition. If silver brazed to a die backing, such ELKONITE® materials should be heat treated after brazing. These harder grades are used primarily for electroforging and electrical upsetting dies, where temperatures and pressures are comparatively high.

ELKONITE® TC20 and TC53 materials are extremely hard and wear resistant. ELKONITE® TC20 material, while somewhat difficult to machine, may be machined using carbide tipped tools. ELKONITE® TC53 material is a heat treatable grade of such high hardness that machining operations are impractical and the material must be ground. Such ELKONITE® materials are customarily used for special applications of electrical upsetting and electroforging.

ELKON® 100W is extremely hard and its ductility is relatively low. It cannot be machined but may be ground to the required shape. It does not alloy appreciably with nonferrous materials and is used for cross-wire welding of metals such as copper and brass. It is also used for electro brazing electrode material and for some electrical upsetting operations.

ELKON® 100M is used principally for electro brazing electrode material and for cross-wire welding of nonferrous metals. It is not as hard as ELKON® 100W material and may be machined or drilled to fit the parts to be joined. A typical application of this material, as an electrode, is the welding or brazing of braided or solid copper conductors to ferrous or nonferrous terminals, lugs or fittings.

ANVILOY® 1150 material is used in electro brazing applications where heat balance is important. The ANVILOY® 1150 material also has good anti-sticking qualities and good high temperature abrasion and hardness properties. The oxidation resistance of both materials is excellent up to 1100°F.

CONVERSION TABLES INCHES INTO MILLIMETERS



NSRW Co., Inc. (800) 933-6779, FAX: (205) 663-3221 Authorized Distributor CMW Inc.

Due to the current move to convert or switch from inches to the metric system as a universal measuring system we are including the three tables below to allow conversion from inches into millimeters.

Examples:

Convert 0.588 inches into millimeters
 From Table I 0.580 inches = 14.73 millimeters
 From Table I 0.008 inches = 0.203 millimeters
 Total 0.588 inches = 14.933 millimeters

Convert 3.065 inches into millimeters
 From Table II 3 inches = 76.2002 millimeters
 From Table I 0.060 inches = 1.524 millimeters
 From Table I 0.005 inches = 0.127 millimeters
 Total 3.065 inches = 77.8512 millimeters

Convert 2-51/64 inches into millimeters
 From Table II 2-25/32 inches = 70.6439 millimeters
 From Table II 1/64 inches = 0.3969 millimeters
 Total 2-51/64 inches = 71.0408 millimeters

**TABLE I
Decimals of
an inch into
millimeters**

Inches	Milli- meters	Inches	Milli- meters
0.001	0.025	0.460	11.68
0.002	0.051	0.470	11.94
0.003	0.076	0.480	11.94
0.004	0.102	0.490	12.45
0.005	0.127	0.500	12.70
0.006	0.152	0.510	12.95
0.007	0.178	0.520	13.21
0.008	0.203	0.530	13.26
0.009	0.229	0.540	13.72
0.010	0.254	0.550	13.97
0.020	0.508	0.560	14.22
		0.570	14.48
0.030	0.762	0.580	14.73
0.040	1.016	0.590	14.99
0.050	1.270	0.600	15.24
0.060	1.524	0.610	15.49
0.070	1.778	0.620	15.75
0.080	2.032	0.630	16.00
0.090	2.286	0.640	16.26
0.100	2.540	0.650	16.51
0.110	2.794	0.660	16.76
0.120	3.048	0.670	17.02
0.130	3.302	0.680	17.27
0.140	3.556	0.690	17.53
0.150	3.810	0.700	17.78
0.160	4.064	0.710	18.03
0.170	4.318	0.720	18.29
0.180	4.572	0.730	18.54
0.190	4.826	0.740	18.80
0.200	5.080	0.750	19.05
0.210	5.334	0.760	19.30
0.220	5.588	0.770	19.56
0.230	5.842	0.780	19.81
0.240	6.096	0.790	20.07
0.250	6.350	0.800	20.32
0.260	6.604	0.810	20.57
0.270	6.858	0.820	20.83
0.280	7.112	0.830	21.08
0.290	7.366	0.840	21.34
0.300	7.620	0.850	21.59
0.310	7.874	0.860	21.84
0.320	8.128	0.870	22.10
0.330	8.382	0.880	22.35
0.340	8.636	0.890	22.61
0.350	8.890	0.900	22.86
0.360	9.144	0.910	23.11
0.370	9.398	0.920	23.37
0.380	9.652	0.930	23.62
0.390	9.906	0.940	23.88
0.400	10.160	0.950	24.13
0.410	10.414	0.960	24.38
0.420	10.668	0.970	24.64
0.430	10.922	0.980	24.89
0.440	11.176	0.990	25.15
0.450	11.430	1.000	25.40

For Taper
Dimensions
in inches
and
millimeters
see Page 7.

**TABLE II
Fractions of
an inch into
millimeters**

Inches	Milli- meters	Inches	Milli- meters
1/64	0.3969	33/64	13.0969
1/32	0.7937	17/32	13.4937
3/64	1.1906	35/64	13.8906
1/16	1.5875	9/16	14.2875
5/64	1.9844	37/64	14.6844
3/32	2.3812	19/32	15.0812
7/64	2.7781	39/64	15.4781
1/8	3.1750	5/8	15.8750
9/64	3.5719	41/64	16.2719
5/32	3.9687	21/32	16.6687
11/64	4.3656	43/64	17.0656
3/16	4.7625	11/16	17.4625
13/64	5.1594	45/64	17.8594
7/32	5.5562	23/32	18.2562
15/64	5.9531	47/64	18.6531
1/4	6.3500	3/4	19.0500
17/64	6.7469	49/64	19.4469
9/32	7.1437	25/32	19.8437
19/64	7.5406	51/64	20.2406
5/16	7.9375	13/16	20.6375
21/64	8.3344	53/64	21.0344
11/32	8.7312	27/32	21.4312
23/64	9.1281	55/64	21.8281
3/8	9.5250	7/8	22.2250
25/64	9.9219	57/64	22.6219
13/32	10.3187	29/32	23.0187
27/64	10.7156	59/64	23.4156
7/16	11.1125	15/16	23.8125
29/64	11.5094	61/64	24.2094
15/32	11.9062	31/32	24.6062
31/64	12.3031	63/64	25.0031
1/2	12.7000	1	25.4001

**TABLE III
Gage-Decimal-
Millimeter Conver-
sion Chart**

Gage	Decimal	Millimeter
3	.239	6.350
4	.234	5.953
5	.209	5.556
6	.194	5.159
7	.179	4.762
8	.164	4.365
9	.150	3.968
10	.135	3.571
11	.120	3.175
12	.105	2.778
13	.090	2.381
14	.075	1.984
15	.067	1.778
16	.060	1.587
17	.054	1.422
18	.048	1.270
19	.042	1.118
20	.036	.965
21	.033	.865
22	.030	.793
23	.027	.711
24	.024	.635
25	.021	.559
26	.018	.483
27	.016	.432
28	.015	.396
29	.014	.356
30	.012	.330
31	.011	.279
32	.010	.254
33	.009	.229
34	.0082	.216
35	.008	.203
36	.007	.178
37	.0064	.168
38	.006	.152

TAPER DIMENSIONS AND ELECTRODE CODING

NSRW Co., Inc. (800) 933-6779, FAX: (205) 663-3221 Authorized Distributor CMW Inc.



Standard Tapered Electrode Theoretical Dimensions	Taper Size	Standard Male Taper Cap taper Dimensions
	4RW 1MT	
	5RW 2MT	
	6RW	
	7RW 3MT	

Drawings Full Size

CMW CODING FOR STRAIGHT TAPERED ELECTRODES

Material	Nose	Attachment	Length
1 = CMW® 28	1 = Dome	1 = No. 4RW	1 = 1"
3 = CMW® 3	2 = Pointed	No. 1MT	2 = 1 1/4"
5 = CMW® 100	3 = Flat		3 = 1 1/2"
6 = ELKONITE® 10W3	4 = Offset	2 = No. 5RW	4 = 1 3/4"
7 = ELKONITE® TC5	5 = 2" Sph. R	No. 2MT	5 = 2"
8 = ELKON® 100M	6 = 10" Sph. R.		6 = 2 1/4"
9 = ELKON® 100W	7 = Truncated	3 = No. 7RW	7 = 2 1/2"
	8 = 3" Sph. R	No. 3MT	8 = 2 3/4"
	9 = 4" Sph. R		9 = 3"
	0 = Shank for Male Cap	4 = No. 6RW	12 = 3 1/4"
			14 = 3 1/2"
			16 = 3 3/4"
			18 = 4"
			20 = 4 1/4"
			22 = 4 1/2"

Note: Prefix MP = Shank for Female Cap

RWMA CODING FOR STRAIGHT TAPERED ELECTRODES

Nose	Material	Attachment	Length in no. of 1/4"
A = Pointed	1 = RWMA CL 1 CMW® 28	4 = No. 4RW No. 1MT	04 = 1" 05 = 1 1/4" 06 = 1 1/2" 07 = 1 3/4"
B = Dome		5 = No. 5RW No. 2MT	08 = 2" 09 = 2 1/4" 10 = 2 1/2" 11 = 2 3/4"
C = Flat	2 = RWMA CL 2 CMW® 3		12 = 3" 13 = 3 1/4" 14 = 3 1/2" 15 = 3 3/4"
D = Offset	3 = RWMA CL 3 CMW® 100	6 = No. 6RW	16 = 4" 17 = 4 1/4" 18 = 4 1/2"
E = Truncated		7 = No. 7RW No. 3MT	

CAPELECTRODES

NSRW Co., Inc. (800) 933-6779, FAX: (205) 663-3221 Authorized Distributor CMW Inc.



These economical, quick change caps are made of long-lasting, highly-efficient CMW[®] 28, CMW[®] 3, and CMW[®] 328 ALLOYS, precision manufactured to exacting tolerances in a wide range of standard configurations or to your special requirements

CMW FEMALE CAP ELECTRODES

ALL DIM. MARKED WITH AN (*) ARE COMMON TO EACH CAP IN A HORIZONTAL LINE.

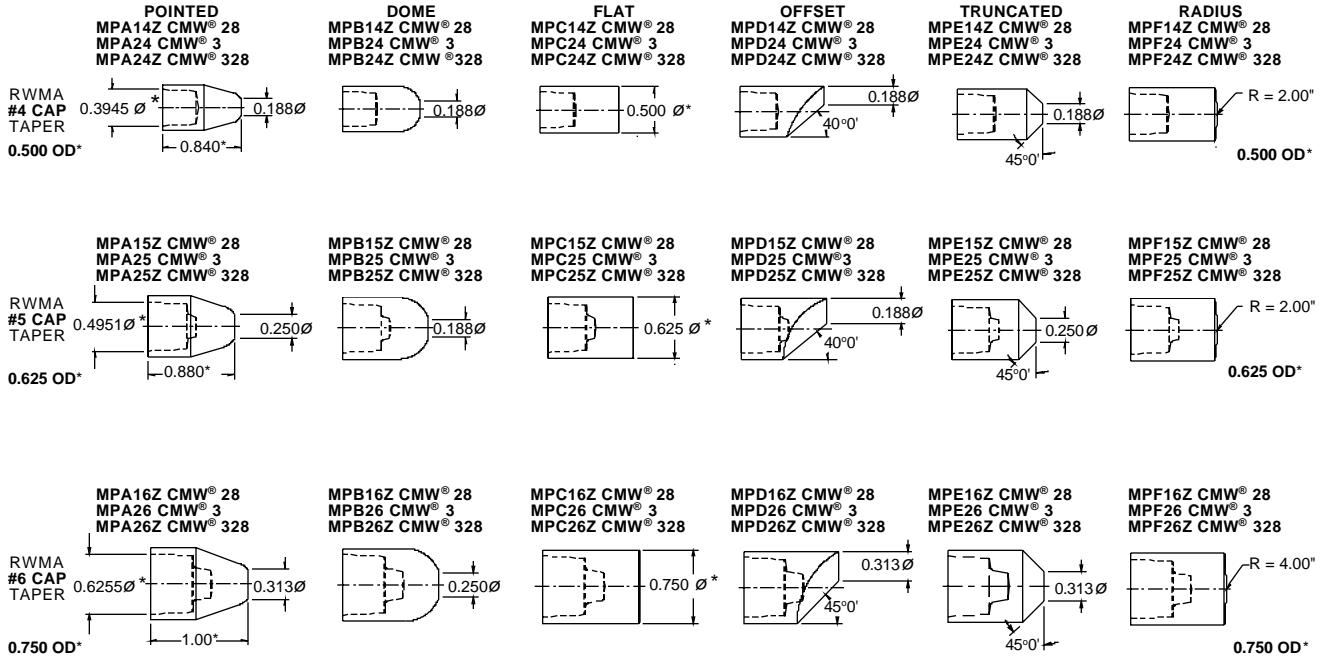

CMW MALE CAP ELECTRODES

ALL DIM. MARKED WITH AN (*) ARE COMMON TO EACH CAP IN A HORIZONTAL LINE.

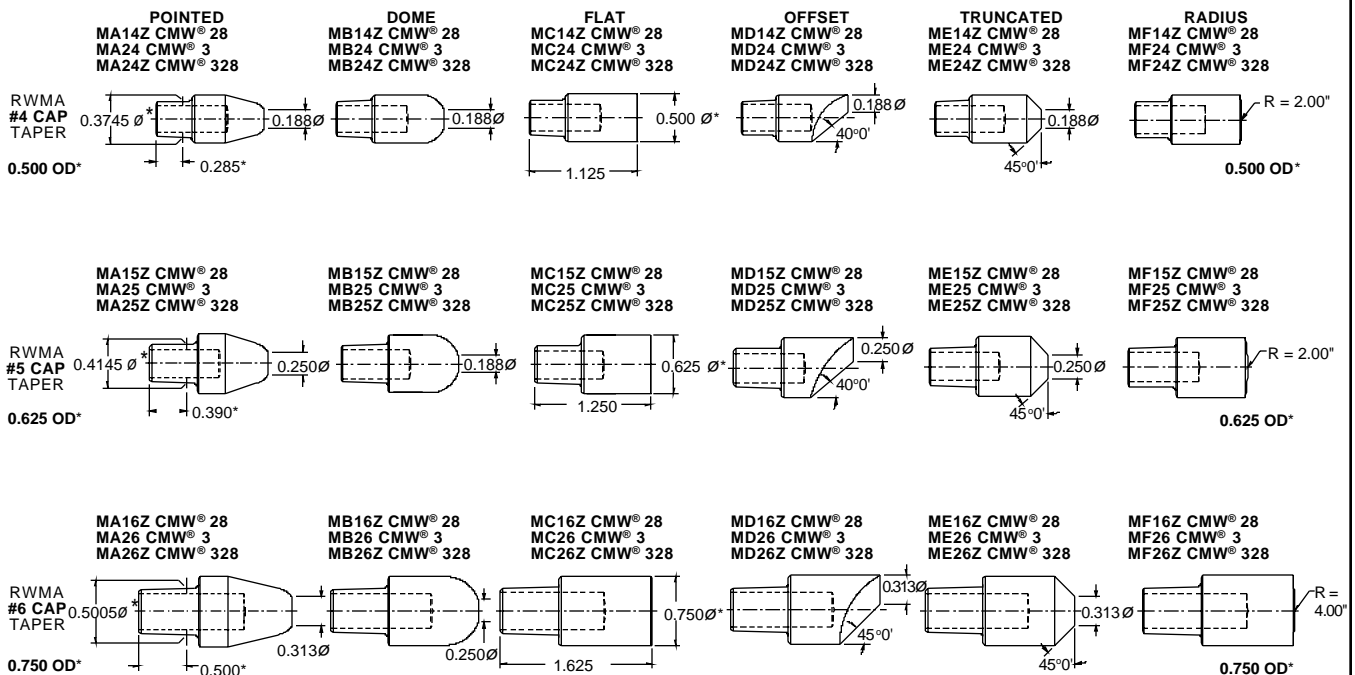

CMW GCAP® ELECTRODES

NSRW Co., Inc. (800) 933-6779, FAX: (205) 663-3221 Authorized Distributor CMW Inc.



The CMW GCAP®* electrode is the answer to welding galvanized steels. The GCAP's® revolutionary design, and precision manufacturing from CMW Engineering provides for no sticking from the very first weld. GCAP® electrode nuggets meet or exceed industry standards for high quality welds from the first weld through the life of the cap. This cap design made from R.W.M.A. class 2 material eliminates brass build-up by literally rolling the brass away. You will use

less electric power (up to 25% less) and still achieve superior welds due to GCAP® design. Productivity will increase with up to 10 times more welds without dressing.

For best use of CMW GCAPS®, a stepper program is recommended. Consult CMW application engineering.

*U.S. Patent 4,954,687; 5,015,816; 5,126,528.

Other patents pending.

CMW GCAP® FEMALE CAP ELECTRODES

ALL DIM. MARKED WITH AN (*) ARE COMMON TO EACH CAP IN A HORIZONTAL LINE.

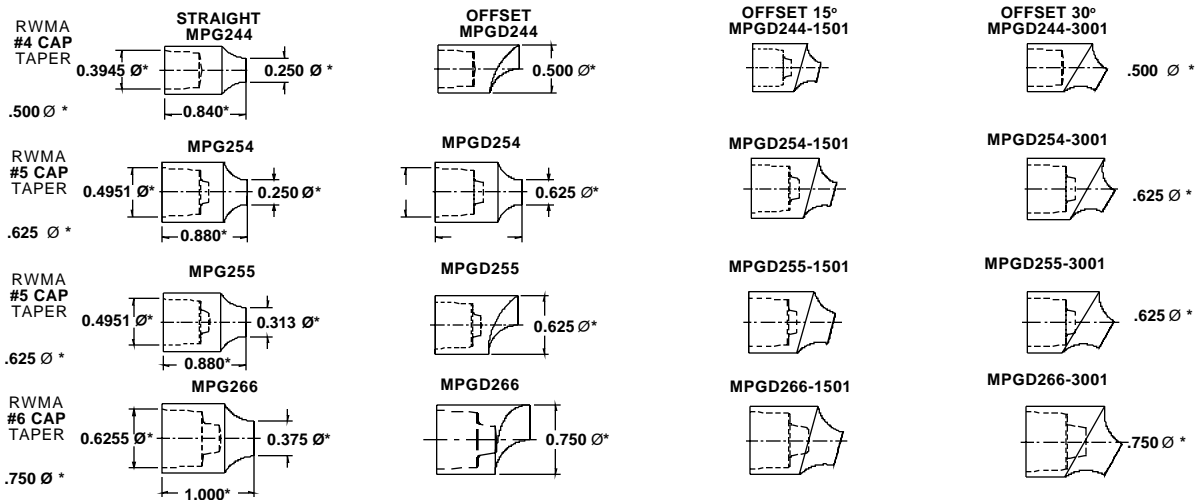

CMW GCAP® MALE CAP ELECTRODES

ALL DIM. MARKED WITH AN (*) ARE COMMON TO EACH CAP IN A HORIZONTAL LINE.

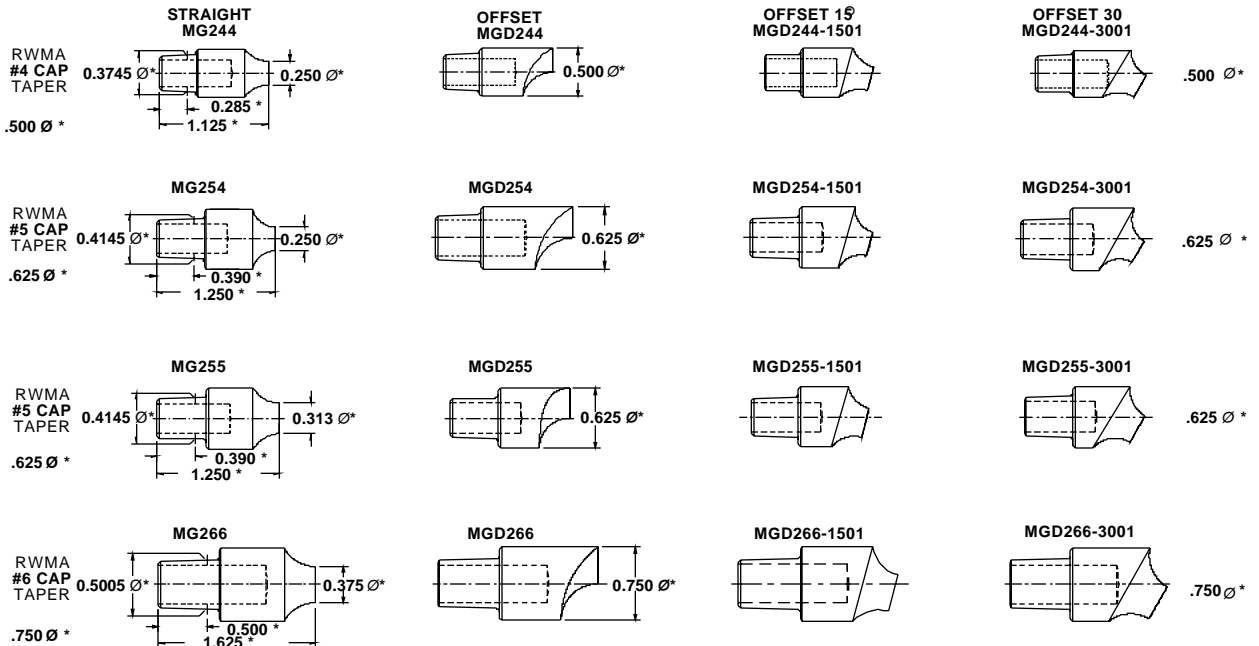

SHANKS FOR FEMALE CAPS



NSRW Co., Inc. (800) 933-6779, FAX: (205) 663-3221 Authorized Distributor CMW Inc.

CMW shanks are precision manufactured from CMW®3 class 2 material to provide a high quality mount for cap type electrodes. They are designed for high strength and electrical conductivity.

These shanks are shown with a blind water hole for cap replacement without shutting off water. Shanks with through water holes are available, by adding "TH" to the basic part number. Example; MP30212TH.

Shanks for female caps with #4 RWMA tapers			Bent offset shanks for female caps with #4 RWMA tapers			
PART NO.*	A DIM.	B DIM.	PART NO.*	A DIM.	B DIM.	C DIM.
MP3012	1.25	1.75	MP3019-08	2.62	3.28	.50
MP3013	1.50	2.00	MP3019-12	2.56	3.22	.75
MP3014	1.75	2.25	MP30112-12	2.81	3.47	.75
MP3015	2.00	2.50	MP30112-16	2.37	3.03	1.00
MP3016	2.25	2.75	MP30116-16	2.87	3.53	1.00
MP3017	2.50	3.00	MP30116-20	2.60	3.28	1.25
MP3018	2.75	3.25				
MP3019	3.00	3.50				
MP30112	3.25	3.75				
MP30114	3.50	4.00				
MP30116	3.75	4.25				
MP30118	4.00	4.50				

Shanks for female caps with #5 RWMA tapers			Bent offset shanks for female caps with #5 RWMA tapers			
PART NO.*	A DIM.	B DIM.	PART NO.*	A DIM.	B DIM.	C DIM.
MP3023	1.46	2.00	MP3029-08	2.58	3.20	.50
MP3024	1.71	2.25	MP3029-12	2.60	3.12	.75
MP3025	1.96	2.50	MP30212-12	2.77	3.44	.75
MP3026	2.21	2.75	MP30212-16	2.33	3.00	1.00
MP3027	2.46	3.00	MP30214-12	3.00	3.66	.75
MP3028	2.71	3.25	MP30214-16	2.81	3.48	1.00
MP3029	2.96	3.50	MP30216-16	2.83	3.49	1.00
MP30212	3.21	3.75	MP30216-20	2.77	3.43	1.25
MP30214	3.46	4.00				
MP30216	3.71	4.25				
MP30218	3.96	4.50				
MP30220	4.21	4.75				
MP30222	4.46	5.00				

Shanks for female caps with #6 RWMA tapers			Bent offset shanks for female caps with #6 RWMA tapers			
PART NO.*	A DIM.	B DIM.	PART NO.*	A DIM.	B DIM.	C DIM.
MP3044	1.64	2.25	MP3049-08	2.69	3.30	.50
MP3045	1.89	2.50	MP30412-12	2.81	3.42	.75
MP3046	2.14	2.75	MP30414-12	2.94	3.55	.75
MP3047	2.39	3.00	MP30416-16	3.06	3.67	1.00
MP3048	2.64	3.25	MP30420-20	3.25	3.86	1.25
MP3049	2.89	3.50				
MP30412	3.14	3.75				
MP30414	3.39	4.00				
MP30416	3.64	4.25				
MP30418	3.89	4.50				
MP30420	4.14	4.75				
MP30422	4.39	5.00				

SHANKS FOR MALE CAPS



CMW shanks are precision manufactured from CMW®3 class 2 material to provide a high quality mount for cap electrodes. They are designed for high strength and electrical conductivity.

Shanks for male caps with #4 RWMA tapers

PART NO. *	A DIM.	B DIM.
3012	1.25	1.88
3013	1.50	2.12
3014	1.75	2.38
3015	2.00	2.62
3016	2.25	2.88
3017	2.50	3.12
3018	2.75	3.38
3019	3.00	3.62
30112	3.25	3.88
30114	3.50	4.12
30116	3.75	4.38
30118	4.00	4.62

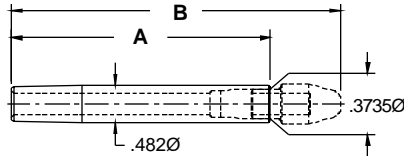

Bent offset shanks for male caps with #4 RWMA tapers

PART NO. *	A DIM.	B DIM.	C DIM.
3019-08	2.62	3.37	.50
3019-12	2.56	3.31	.75
30112-12	2.81	3.56	.75
30112-16	2.37	3.12	1.00
30116-16	2.87	3.62	1.00
30116-20	2.62	3.37	1.25

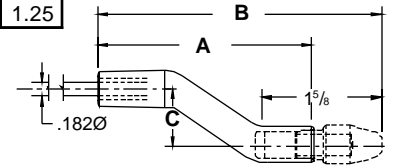

Bent Dimensions for Reference Only

Shanks for male caps with #5 RWMA tapers

PART NO. *	A DIM.	B DIM.
3022	1.25	2.00
3023	1.50	2.25
3024	1.75	2.50
3025	2.00	2.75
3026	2.25	3.00
3027	2.50	3.25
3028	2.75	3.50
3029	3.00	3.75
30212	3.25	4.00
30214	3.50	4.25
30216	3.75	4.50
30218	4.00	4.75
30220	4.25	5.00
30222	4.50	5.25

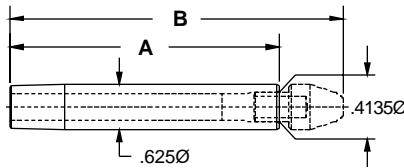

Bent offset shanks for male caps with #5 RWMA tapers

PART NO. *	A DIM.	B DIM.	C DIM.
3028-08	2.37	3.12	.50
3028-12	2.31	3.06	.75
30212-12	2.81	3.56	.75
30212-16	2.37	3.12	1.00
30214-12	3.06	3.81	.75
30214-16	2.62	3.37	1.00
30214-20	2.37	3.12	1.25
30216-16	2.87	3.62	1.00
30216-20	2.62	3.37	1.25

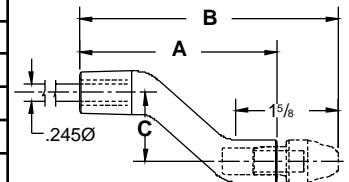

Bent Dimensions for Reference Only

Shanks for male caps with #6 RWMA tapers

PART NO. *	A DIM.	B DIM.
3043	1.50	2.62
3044	1.75	2.88
3045	2.00	3.12
3046	2.25	3.38
3047	2.50	3.62
3048	2.75	3.88
3049	3.00	4.12
30412	3.25	4.38
30414	3.50	4.62
30416	3.75	4.88
30418	4.00	5.12
30420	4.25	5.38
30422	4.50	5.62

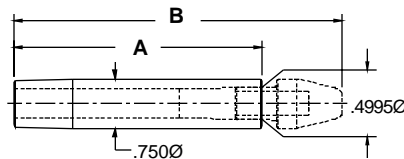

Bent offset shanks for male caps with #6 RWMA tapers

PART NO. *	A DIM.	B DIM.	C DIM.
30412-08	2.62	3.75	.50
30412-12	2.56	3.69	.75
30414-12	2.75	3.88	.75
30416-16	2.87	4.00	1.00
30420-20	3.12	4.25	1.25

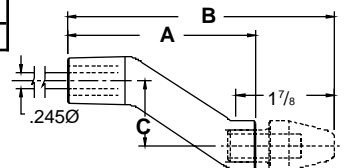

Bent Dimensions for Reference Only

STRAIGHT ELECTRODES



NSRW Co., Inc. (800) 933-6779, FAX: (205) 663-3221 Authorized Distributor CMW Inc.

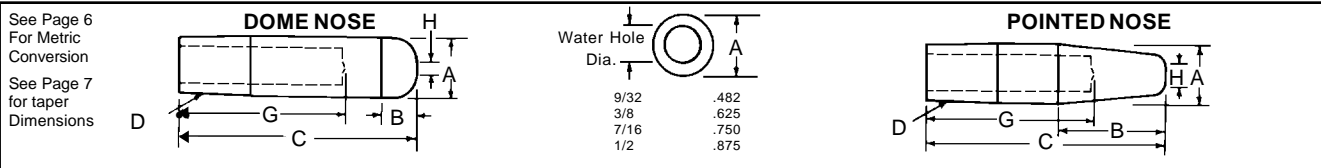

CMW® 28 Part No.	CMW® 3 Part No.	CMW® 100 Part No.	Nose Length B	Face Dia. H	Major Dia. A	Overall Length C	Taper D	Hole Depth G	CMW® 28 Part No.	CMW® 3 Part No.	CMW® 100 Part No.	Nose Length B	Face Dia. H
Class 1	Class 2	Class 3							Class 1	Class 2	Class 3		

4RW (# 1MT)

1111	3111	5111	13/64	3/16	.482	1	4RW	5/8	1211	3211	5211	3/8	3/16
1112	3112	5112	1/4			1-1/4		3/4	1212	3212	5212	3/8	
1113	3113	5113	1/4			1-1/2		1	1213	3213	5213	5/8	
1114	3114	5114	1/4			1-3/4		1-1/4	1214	3214	5214	3/4	
1115	3115	5115				2		1-1/2	1215	3215	5215		
1116	3116	5116				2-1/4		1-3/4	1216	3216	5216		
1117	3117	5117	1/4			2-1/2		2	1217	3217	5217	3/4	
1118	3118	5118				2-3/4		2-1/4	1218	3218	5218		
1119	3119	5119				3		2-1/2	1219	3219	5219		
11112	31112	51112	1/4			3-1/4		2-3/4	12112	32112	52112	3/4	
11114	31114	51114				3-1/2		3	12114	32114	52114		
11116	31116	51116				3-3/4		3-1/4	12116	32116	52116		
11118	31118	51118		1/4	4	3-1/2	12118	32118	52118	3/4			

5RW (# 2MT)

1122	3122	5122	3/8	1/4	.625	1-1/4	5RW	3/4	1222	3222	5222	1/2	1/4
1123	3123	5123				1-1/2		3/4	1223	3223	5223	3/4	
1124	3124	5124				1-3/4		1	1224	3224	5224	3/4	
1125	3125	5125	3/8			2		1-1/4	1225	3225	5225	1-1/8	
1126	3126	5126				2-1/4		1-1/2	1226	3226	5226		
1127	3127	5127				2-1/2		1-3/4	1227	3227	5227		
1128	3128	5128	3/8			2-3/4		2	1228	3228	5228	1-1/8	
1129	3129	5129				3		2-1/4	1229	3229	5229		
11212	31212	51212				3-1/4		2-1/2	12212	32212	52212		
11214	31214	51214	3/8			3-1/2		2-3/4	12214	32214	52214	1-1/8	
11216	31216	51216				3-3/4		3	12216	32216	52216		
11218	31218	51218				4		3-1/4	12218	32218	52218		
11220	31220	51220	3/8	4-1/4	3-1/2	12220	32220	52220	1-1/8				
11222	31222	51222		4-1/2	3-3/4	12222	32222	52222					

Electrodes of other tapers and alloys available upon request.

STRAIGHT ELECTRODES

NSRW Co., Inc. (800) 933-6779, FAX: (205) 663-3221 Authorized Distributor CMW Inc.



See Page 6 For Metric Conversion See Page 7 for taper Dimensions	FLAT NOSE				OFFSET NOSE								
	CMW® 28 Part No.	CMW® 3 Part No.			CMW® 100 Part No.	Face Dia. H		Major Dia. A	Overall Length C	Taper D	Hole Depth G	CMW® 28 Part No.	CMW® 3 Part No.
Class 1	Class 2	Class 3							Class 1	Class 2	Class 3		

4RW (# 1MT)

1311	3311	5311	.482	.482	1	4RW	5/8	1411	3411	5411	45°	3/16
1312	3312	5312			1-1/4		1412	3412	5412	40°		
1313	3313	5313			1-1/2		1413	3413	5413	30°		
1314	3314	5314			1-3/4	OR	1-1/4	1414	3414	5414	30°	
1315	3315	5315			2		1-1/2	1415	3415	5415		
1316	3316	5316			2-1/4		1-3/4	1416	3416	5416		
1317	3317	5317			2-1/2	1MT	2	1417	3417	5417	30°	
1318	3318	5318			2-3/4		2-1/4	1418	3418	5418		
1319	3319	5319			3		2-1/2	1419	3419	5419		
13112	33112	53112			3-1/4	OR	2-3/4	14112	34112	54112	30°	
13114	33114	53114			3-1/2		3	14114	34114	54114		
13116	33116	53116			3-3/4		3-1/4	14116	34116	54116		
13118	33118	53118	4	3-1/2	14118	34118	54118	30°				

5RW (# 2MT)

1322	3322	5322	5/8	.625	1-1/4	5RW	3/4	1422	3422	5422	40°	1/4
1323	3323	5323			1-1/2		1423	3423	5423	40°		
1324	3324	5324			1-3/4		1424	3424	5424	30°		
1325	3325	5325			2	OR	1-1/4	1425	3425	5425	30°	
1326	3326	5326			2-1/4		1-1/2	1426	3426	5426		
1327	3327	5327			2-1/2		1-3/4	1427	3427	5427		
1328	3328	5328			2-3/4	2MT	2	1428	3428	5428	30°	
1329	3329	5329			3		2-1/4	1429	3429	5429		
13212	33212	53212			3-1/4		2-1/2	14212	34212	54212		
13214	33214	53214			3-1/2	OR	2-3/4	14214	34214	54214	30°	
13216	33216	53216			3-3/4		3	14216	34216	54216		
13218	33218	53218			4		3-1/4	14218	34218	54218		
13220	33220	53220	4-1/4	OR	3-1/2	14220	34220	54220	30°			
13222	33222	53222	4-1/2		3-3/4	14222	34222	54222				

Electrodes of other tapers and alloys available upon request.

STRAIGHT ELECTRODES

NSRW Co., Inc. (800) 933-6779, FAX: (205) 663-3221 Authorized Distributor CMW Inc.



See Page 6
For Metric
Conversion
See Page 7
for taper
Dimensions

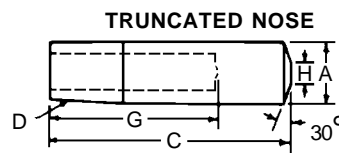
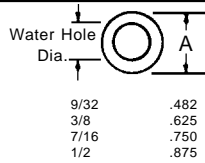
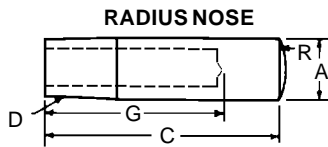

CMW® 28 Part No.	CMW® 3 Part No.	CMW® 100 Part No.	Major Dia. A	Overall Length C	Taper D	Hole Depth G	Spherical Radius R
Class 1	Class 2	Class 3					
1523	3523	5523	.625	1-1/2	5RW	3/4	2
1525	3525	5525		2		1-1/4	
1527	3527	5527		2-1/2		1-3/4	
1529	3529	5529		3		2-1/4	
15218	35218	55218		4		3-1/4	
1623	3623	5623		1-1/2		2MT	
1625	3625	5625		2	1-1/4		
1627	3627	5627		2-1/2	1-3/4		
1629	3629	5629		3	2-1/4		
16218	36218	56218		4	3-1/4		
1825	3825	5825		2	1-1/4		3
1829	3829	5829		3	2-1/4		
1925	3925	5925	2	3	1-1/4	4	
1929	3929	5929					2-1/4

CMW® 28 Part No.	CMW® 3 Part No.	CMW® 100 Part No.	Major Dia. A	Overall Length C	Taper D	Hole Depth G	Face Diam. H
Class 1	Class 2	Class 3					
1712	3712	5712	.482	1-1/4	4RW	3/4	3/16
1713	3713	5713		1-1/2		1	
1715	3715	5715		2		1-1/2	
1717	3717	5717		.625	2-1/2	1MT	2
1718	3718	5718			2-3/4	2-1/4	
1723	3723	5723			1-1/2	3/4	1/4
1725	3725	5725	2	1-1/4			
1727	3727	5727	2-1/2	1-3/4			
1729	3729	5729	3	2MT	2-1/4	3-1/4	
17218	37218	57218					4

CMW® 28 Part No.	CMW® 3 Part No.	Major Dia. A	Overall Length C	Taper D	Hole Depth G	Face Dia. H
Class 1	Class 2					
16-2491	16-2494	.482	2	4RW 1MT	1-1/2	1/4
16-2492	16-2495	.625	2-1/2	5RW 2MT	2	3/8
16-2493	16-2496	.875	3	7RW 3MT	2-1/4	1/2

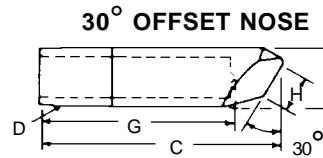

ELKONITE® AND ELKON® FACED STRAIGHT MORSE TAPER ELECTRODES

ELKONITE® 10W3 Face	ELKON® 100M Face	ELKON® 100W Face	Major Dia. A	ELKON® OR ELKONITE® Lg. B	Over all Lg. C	Taper D	Hole Depth G	Face Dia. H
ELKONITE® AND ELKON® DOME NOSE								
611050	811050	911050	.482	3/16	2	4RW 1MT	1-1/2	1/8
612050	812050	912050	.625	1/4	2	5RW 2MT	1-1/2	1/8
ELKONITE® AND ELKON® FLAT NOSE								
631050	831050	931050	.482	3/16	2	4RW 1MT	1-1/2	.482
632030	832050	932050	.625	1/4	2	5RW	1	5/8
632050						1-1/2	1-1/2	
632070						2MT	2	5/8
16-1353			.625	1/4	2-1/2	2MT	5/8	
633050	833050	933050	.875	1/4	2	7RW 3MT	1-1/2	7/8

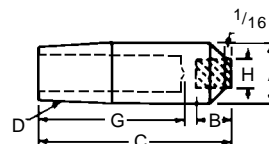
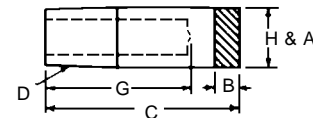
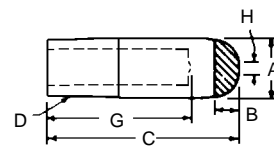

ELKON® CENTERED INSERT NOSE

871050	971050	.482	3/8	2	4RW 1MT	1-1/2	3/16
872050	972050	.625	3/8	2	5RW 2MT	1-1/4	1/4

Electrodes of other tapers and alloys available upon request.
For other ELKONITE® and ELKON® materials see page 5 and for other recommended uses see the chart on page 56.
Electrodes faced with material other than those shown on this page are available to special order.

SINGLE BEND ELECTRODES



NSRW Co., Inc. (800) 933-6779, FAX: (205) 663-3221 Authorized Distributor CMW Inc.

CMW® 3 single bend electrodes are cold formed from full hard straight electrodes, and have properties superior to those obtained by casting or hot forging methods. Cooling tubes are bent in place, if requested, to provide water flow as near to the welding face as in the case of straight electrodes. These extra values assure you a more efficient, less costly electrode for gun welders and special offset welding applications.

Furnished with water tubes as specials to your order. Other nose types available to order. For dimensions not shown here see straight electrode (round water hole) measurements on page 12, 13 and 14. CMW® 28 material available on special order.

SINGLE BEND

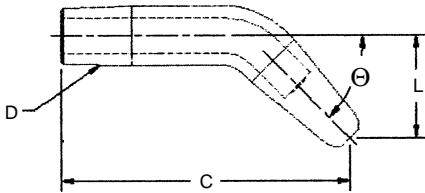

Part No.	Reference Length to \odot of Face "C"	Taper "D"	Offset \odot of Taper to \odot of Face "L"	Bent Angle " Θ "
3214-04-15	1 11/16		1/4	15°
3219-04-15	2 15/16	4RW	1/4	
32118-13-15	3 7/8	1MT	13/16	
3225-04-15	1 7/8		1/4	
3229-04-15	2 7/8	5RW	1/4	
32218-10-15	3 13/16	2MT	5/8	
3215-07-30	1 7/8		7/16	30°
3219-07-30	2 7/8	4RW	7/16	
32118-23-30	3 5/8	1MT	1 7/16	
3226-09-30	2 1/16		9/16	45°
32212-09-30	3 1/16	5RW	9/16	
32220-24-30	3 13/16	2MT	1 1/2	
3215-10-45	1 11/16		5/8	60°
32112-12-45	2 7/8	4RW	3/4	
32118-33-45	3 1/8	1MT	2 1/16	
3228-17-45	2 1/4		1 1/16	75°
32214-17-45	3	5RW	1 1/16	
32220-33-45	3 3/8	2MT	2 1/16	
3218-23-60	2		1 7/16	60°
32116-23-60	3	4RW	1 7/16	
32118-40-60	2 5/8	1MT	2 1/2	
32212-25-60	2 3/8		1 9/16	75°
32218-25-60	3 1/8	5RW	1 9/16	
32220-38-60	3	2MT	2 3/8	
32216-35-75	2 5/16		2 3/16	75°
32220-37-75	2 11/16	5RW	2 5/16	
32220-43-75	2 3/8	2MT	2 11/16	

RADIUS BEND

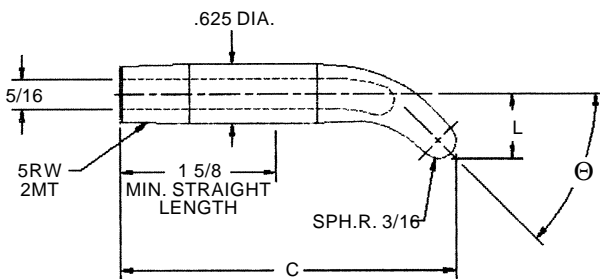

Part No.	O.A.L. "C"	Offset \odot of Taper to Top of Radius "L"	Bent Angle " Θ "
16-26015	3 11/16	3/8	15°
16-26030	3 5/8	33/64	30°
16-26045	3 1/2	43/64	45°
16-26060	3 3/8	27/32	60°
16-26075	3 5/32	1 1/32	75°
16-26090	2 13/16	1 1/4	90°

Radius bend electrodes are designed for use with 18-768 & 18-784 straight universal adapters shown on page #35.

See Page 6 for Metric Conversion
See Page 7 for Taper Dimensions

DOUBLE BEND ELECTRODE CODING SYSTEM

NSRW Co., Inc. (800) 933-6779, FAX: (205) 663-3221 Authorized Distributor CMW Inc.



CMW double bend electrodes are cold formed from full hard straight electrodes, and have properties superior to those obtainable by casting or hot forging methods. Cooling tubes, unless otherwise specified are bent in place to provide coolant flow near the welding face as in the case of straight electrodes. These extra values assure you of longer electrode life, longer runs between dressings, and highest weld quality. CMW® 3 material is standard for these electrodes.

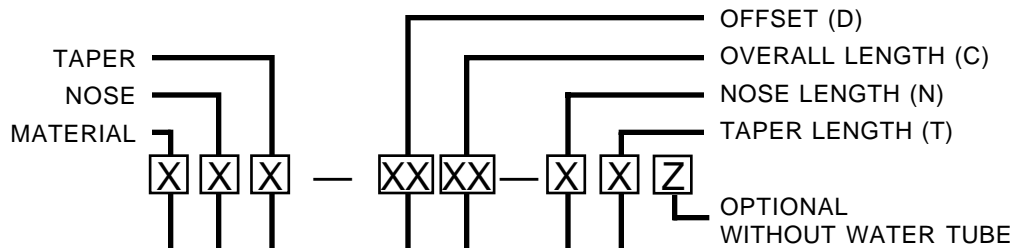
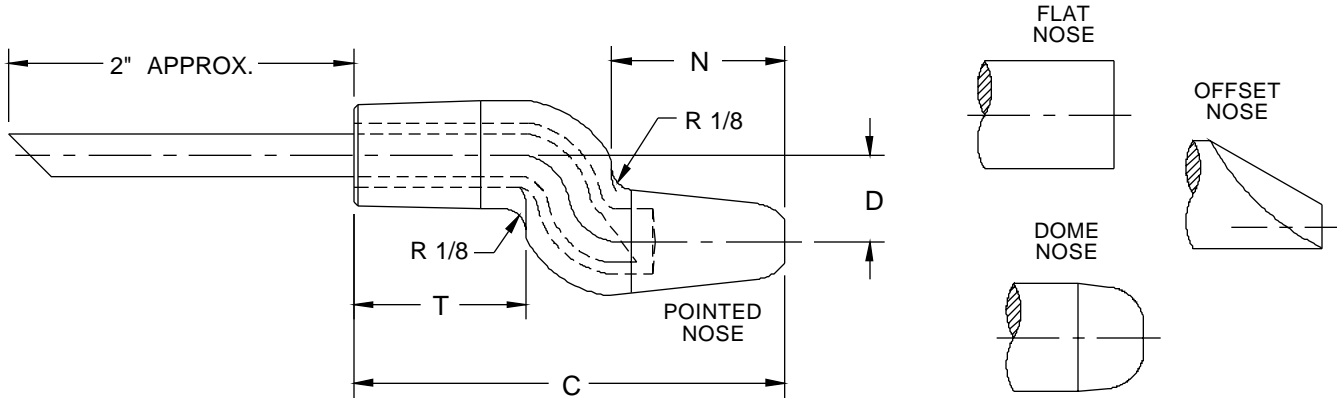

1 = CMW® 28	1 = DOME	1=4RW 1MT	08 = 1/2"	32 = 2"	2 = 3/4"
3=*CMW® 3	2= *POINTED	2=5RW 2MT	12 = 3/4"	36 = 2 1/4"	3 = 7/8"
5= CMW® 100	3= FLAT		16 = 1"	40 = 2 1/2"	4 = 1"
	4= OFFSET		20 = 1 1/4"	44 = 2 3/4"	** 5 = 1 1/8"
			24 = 1 1/2"	48 = 3"	** 6 = 1 1/4"
			28 = 1 3/4"	52 = 3 1/4"	** 7 = 1 1/2"
				56 = 3 1/2"	** 8 = 1 3/4"
				60 = 3 3/4"	** 9 = 2"

* STANDARD

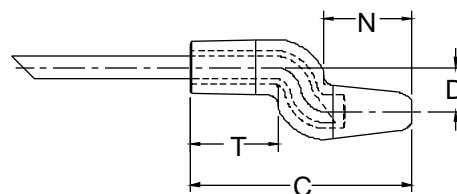
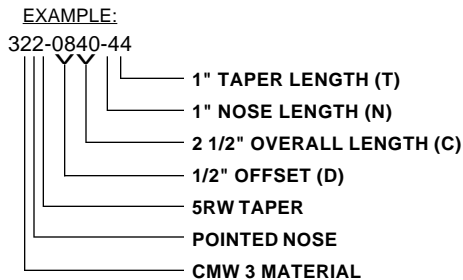

** MAY NOT BE A STOCK ITEM
STANDARD 4RW NOSE LENGTH = 3/4"
STANDARD 4RW TAPER LENGTH = 7/8"
STANDARD 5RW NOSE & TAPER LENGTH = 1"

WATER TUBE SIZE:
4RW - 0.185 O.D.
5RW = 0.245 O.D.

See Page 6 for Metric Conversion
See Page 7 for Taper Dimensions

DOUBLE BEND ELECTRODES



NSRW Co., Inc. (800) 933-6779, FAX: (205) 663-3221 Authorized Distributor CMW Inc.

CMW double bend electrodes are cold formed from full hard straight electrodes, and have properties superior to those obtainable by casting or hot forging methods. Cooling tubes, unless otherwise specified are bent in place to provide coolant flow near the welding face as in the case of straight electrodes. These extra values assure you of longer electrode life, longer runs between dressings, and highest weld quality. CMW® 3 material is standard for these electrodes. CMW® 28, CMW® 100, CMW® 328 available on special order.

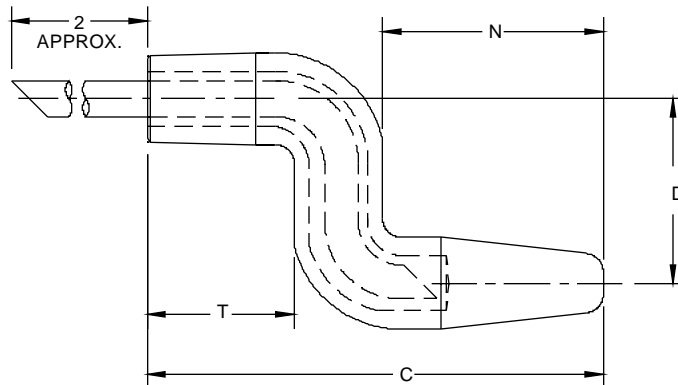

Offset "D"	Taper Size	Nose End "N"	Taper End "T"	Dome Pointed Flat O.A.L. "C"	Pointed Nose Part No.
1/2	4RW 1MT	3/4	7/8	2	321-0832-23
		3/4	7/8	2 1/2	321-0840-23
		2	7/8	3 1/4	321-0852-93
	5RW 2MT	1	1	2 1/2	322-0840-44
		1	1	2 3/4	322-0844-44
		1	1	3 1/4	322-0852-44
		2	1	3 1/2	322-0856-94
3/4	4RW 1MT	3/4	7/8	2	321-1232-23
		3/4	7/8	2 1/2	321-1240-23
		2	7/8	3 1/2	321-1256-93
	5RW 2MT	1	1	2 3/4	322-1244-44
		1	1	3	322-1248-44
		2	1	3 1/2	322-1256-94
1	4RW 1MT	3/4	7/8	2 1/4	321-1636-23
		3/4	7/8	2 3/4	321-1644-23
		1 3/4	7/8	3 1/4	321-1652-83
	5RW 2MT	3/4	7/8	3 1/2	321-1656-23
		1	1	2 3/4	322-1644-44
		1	1	3	322-1648-44
		1	1	3 1/2	322-1656-44
		1 3/4	1	3 1/2	322-1656-84
1 1/4	4RW 1MT	3/4	7/8	2 1/2	321-2040-23
		3/4	7/8	3	321-2048-23
		1 1/2	7/8	3	321-2048-73
	5RW 2MT	1	1	2 3/4	322-2044-44
		1	1	3 1/4	322-2052-44
		1	1	3 1/2	322-2056-44
		1 1/2	1	3 1/2	322-2056-74
		1 3/4	1	3 1/2	322-2056-84
1 1/2	5RW 2MT	1	1	2 3/4	322-2444-44
		1 1/4	1	3	322-2448-64
1 3/4	5RW 2MT	1	1	2 3/4	322-2844-44
		1 1/4	1	3	322-2848-64

See Page 6 for Metric Conversion
See Page 7 for Taper Dimensions

WATER TUBE SIZE:
4RW = 0.185 O.D.
5RW = 0.245 O.D.

CRANKELECTRODES

NSRW Co., Inc. (800) 933-6779, FAX: (205) 663-3221 Authorized Distributor CMW Inc.

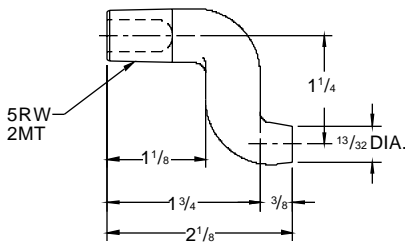

16-38661 CMW® 3
COLD FORMED*

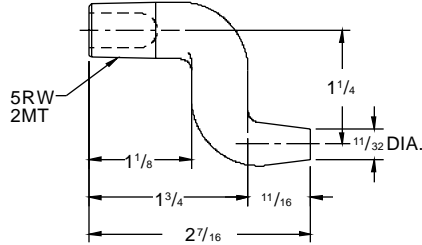

16-3866 CMW® 3
COLD FORMED*

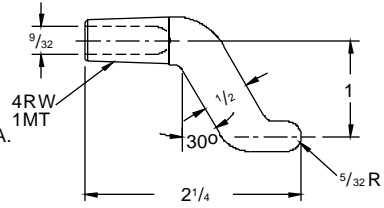

16-3835 CMW® 3
CASTING

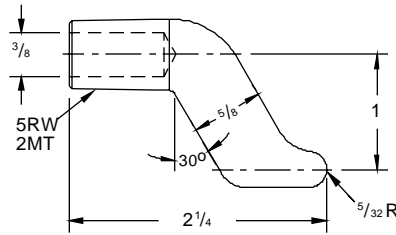

16-3836 CMW® 3
CASTING

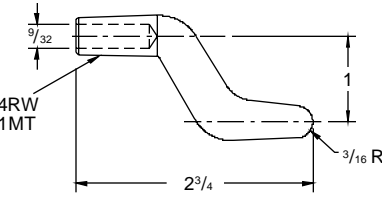

16-3837 CMW® 3
CASTING

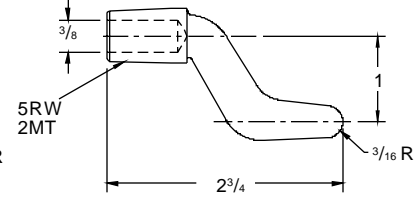

16-3838 CMW® 3
CASTING

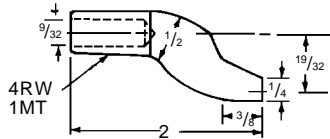

16-3870 CMW® 3
COLD FORMED*

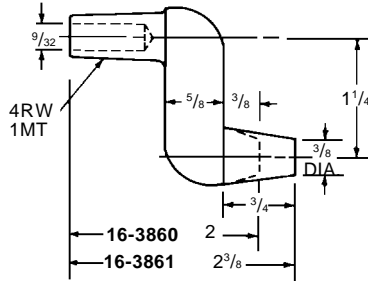

CMW® 3
FORGED

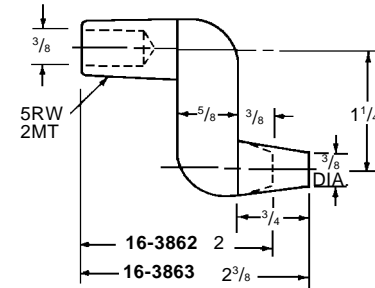

CMW® 3
FORGED

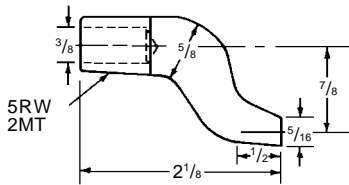

16-3871 CMW® 3
COLD FORMED*

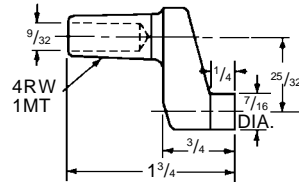

16-3873 CMW® 3
CASTING

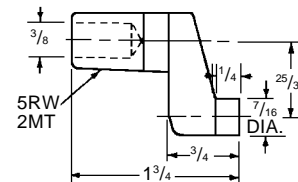

16-3874 CMW® 3
CASTING

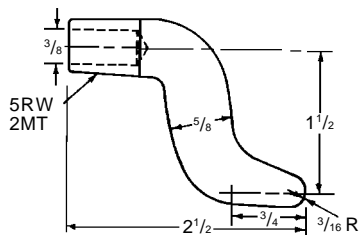

16-38351 CMW® 3
COLD FORMED*

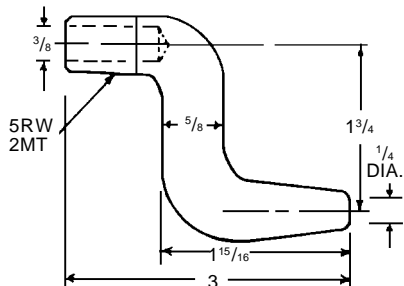

16-38352 CMW® 3
COLD FORMED*

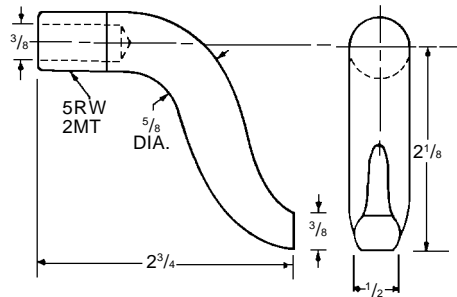

16-38353 CMW® 3
COLD FORMED*

* Optional material available on special order:
CMW® 28, CMW® 100

See Page 6 for Metric conversions See page 7 for Taper dimensions

SPADE AND GUN ELECTRODES



NSRW Co., Inc. (800) 933-6779, FAX: (205) 663-3221 Authorized Distributor CMW Inc.

See page 6 for Metric conversions
See page 7 for Taper dimensions

SPADE ELECTRODES

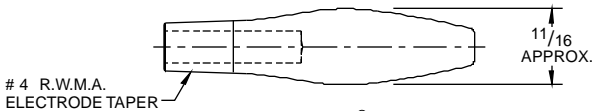
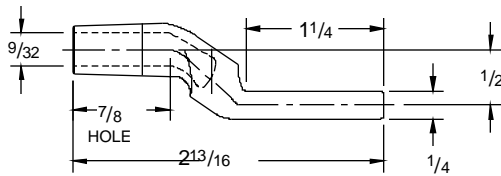
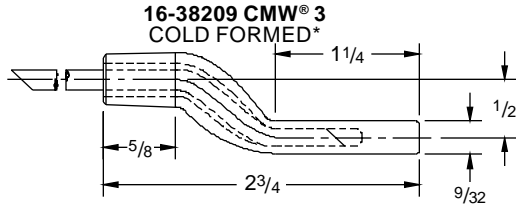
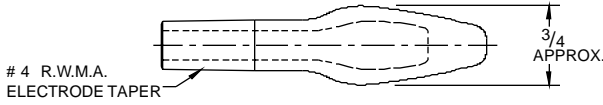
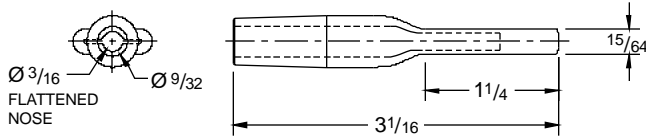

**16-38202 CMW® 3
COLD FORMED***

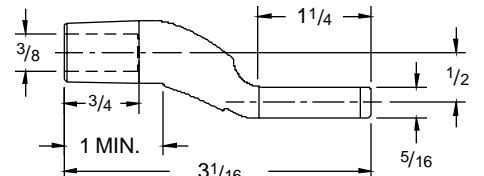
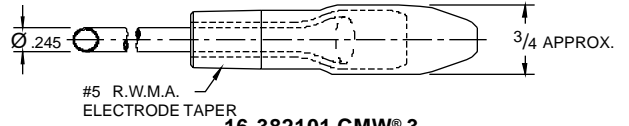
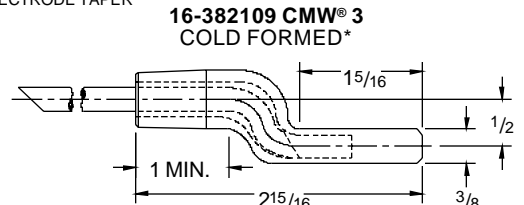
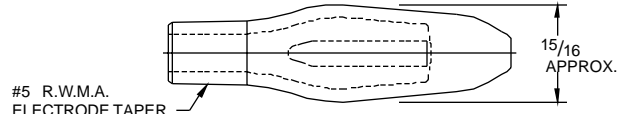
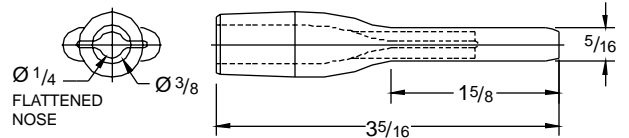

**16-382102 CMW® 3
COLD FORMED***

* Optional material available on special order: CMW@28 & CMW@100

GUN ELECTRODES

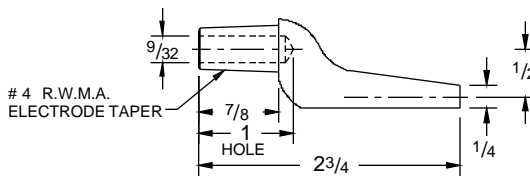

**16-3820 CMW® 3
CASTING**

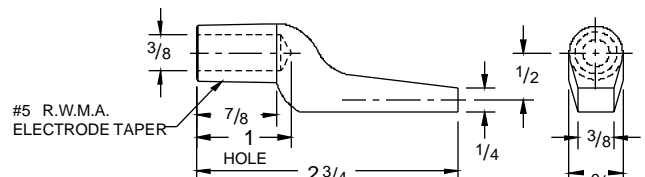

**16-3821 CMW® 3
CASTING**

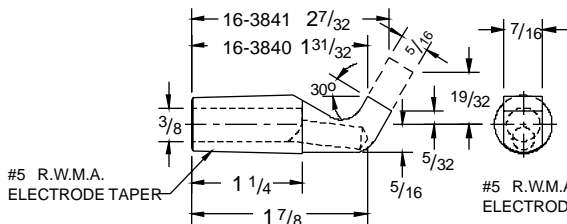

**16-3840 AND
16-3841 CMW® 3
COLD FORMED***

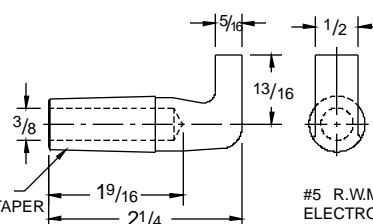

**16-382120 CMW® 3
CASTING**

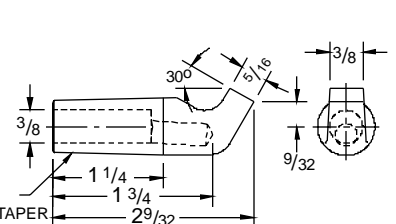

**16-3847 CMW® 3
COLD FORMED***

ORDER BY CMW PART NUMBER ONLY

BENT DIMENSIONS REFERENCE ONLY

CHAMELEON/MAX-LIFE™ NUT WELDING ELECTRODES

NSRW Co., Inc. (800) 933-6779, FAX: (205) 663-3221 Authorized Distributor CMW Inc.

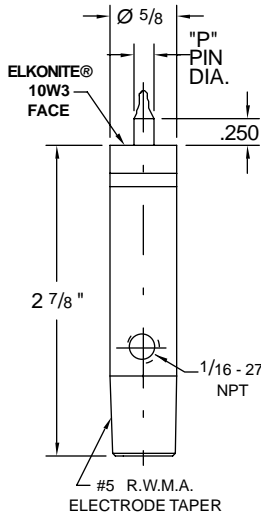

Nut Welding Assemblies	Screw Thread Size	"P"	CMW® 3 Base	Spring	Ceramic Coated Stainless Steel Pin	Elkonite® Faced Cap
16-37725-04	#4	.142	16-37325	16-950078-01	16-950064-04	16-37725-C04
16-37725-05	#5	.158	16-37325	16-950078-01	16-950064-05	16-37725-C05
16-37725-06	#6	.173	16-37325	16-950078-01	16-950064-06	16-37725-C06
16-37725-M4	4MM	.187	16-37325	16-950078-01	16-950064-M4S	16-37725-CM4
16-37725-08	#8	.198	16-37325	16-950078-01	16-950064-08	16-37725-C08
16-37725-10	#10	.220	16-37325	16-950078-01	16-950064-10	16-37725-C10
16-37725-M5	5MM	.226	16-37325	16-950078-01	16-950064-M5S	16-37725-CM5
16-37725-12	#12	.250	16-37325	16-950078-01	16-950064-12	16-37725-C12
16-37725-M6	6MM	.266	16-37325	16-950078-01	16-950064-M6S	16-37725-CM6
16-37725-25	.250	.283	16-37325	16-950078-01	16-950064-25	16-37725-C25

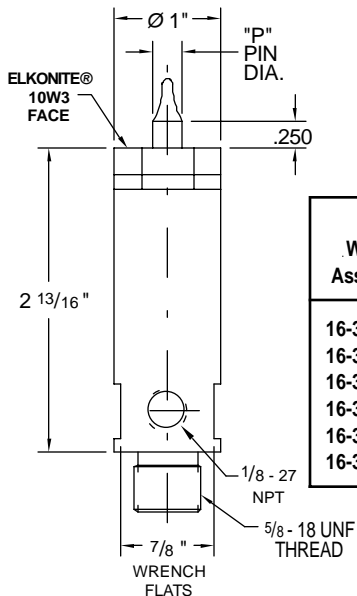

Nut Welding Assemblies	Screw Thread Size	"P"	CMW® 3 Base	Spring	Ceramic Coated Stainless Steel Pin	Elkonite® Faced Cap
16-37825-M4	4MM	.187	16-37825	16-950065-01	16-950064-M4	16-37825-CM4
16-37825-M5	5MM	.226	16-37825	16-950065-01	16-950064-M5	16-37825-CM5
16-37825-M6	6MM	.266	16-37825	16-950065-01	16-950064-M6	16-37825-CM6
16-37825-M7	7MM	.305	16-37825	16-950065-01	16-950064-M7	16-37825-CM7
16-37825-M8	8MM	.344	16-37825	16-950065-01	16-950064-M8	16-37825-CM8
16-37825-M9	9MM	.384	16-37825	16-950065-01	16-950064-M9	16-37825-CM9

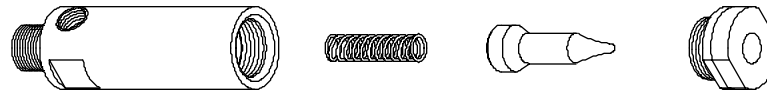
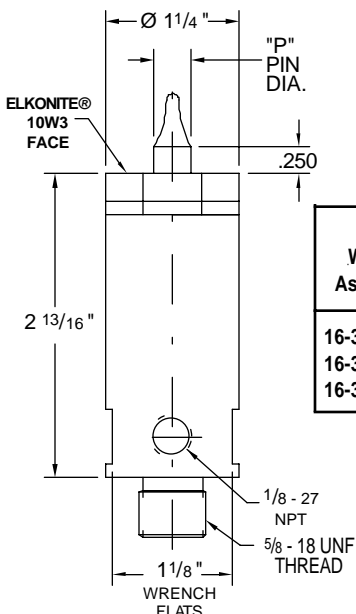

Nut Welding Assemblies	Screw Thread Size	"P"	CMW® 3 Base	Spring	Ceramic Coated Stainless Steel Pin	Elkonite® Faced Cap
16-37826-M10	10MM	.423	16-37826	16-950065-01	16-950064-M10	16-37826-CM10
16-37826-M11	11MM	.463	16-37826	16-950065-01	16-950064-M11	16-37826-CM11
16-37826-M12	12MM	.502	16-37826	16-950065-01	16-950064-M12	16-37826-CM12

CHAMELEON/MAX-LIFE™ STUD WELDING ELECTRODES

NSRW Co., Inc. (800) 933-6779, FAX: (205) 663-3221 Authorized Distributor CMW Inc.

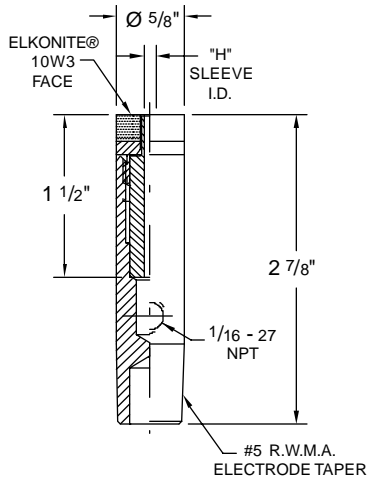

Stud Welding Assemblies	Screw Thread Size	"H"	CMW® 3 Base	Ceramic Coated Stainless Steel Sleeve	Elkonite® Faced Cap
16-37325-116	#4	.116	16-37325	16-953116	16-37325-C116
16-37325-132	#5	.132	16-37325	16-953132	16-37325-C132
16-37325-140	#6	.140	16-37325	16-953140	16-37325-C140
16-37325-169	#8	.169	16-37325	16-953169	16-37325-C169
16-37325-169	4MM	.169	16-37325	16-953169	16-37325-C169
16-37325-191	#10	.191	16-37325	16-953191	16-37325-C191
16-37325-204	5MM	.204	16-37325	16-953204	16-37325-C204
16-37325-220	#12	.220	16-37325	16-953220	16-37325-C220
16-37325-243	6MM	.243	16-37325	16-953243S	16-37325-C243
16-37325-254	.250	.254	16-37325	16-953254S	16-37325-C254

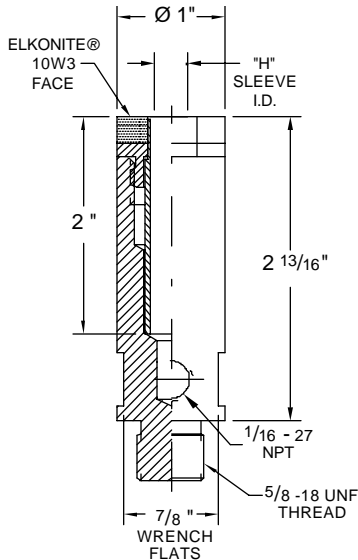

Stud Welding Assemblies	Screw Thread Size	"H"	CMW® 3 Base	Ceramic Coated Stainless Steel Sleeve	Elkonite® Faced Cap
16-37525-243	6MM	.243	16-37825	16-953243	16-37525-C243
16-37525-254	.250	.254	16-37825	16-953254	16-37525-C254
16-37525-320	.312	.320	16-37825	16-953320	16-37525-C320
16-37525-320	8MM	.320	16-37825	16-953320	16-37525-C320
16-37525-380	.375	.380	16-37825	16-953380	16-37525-C380

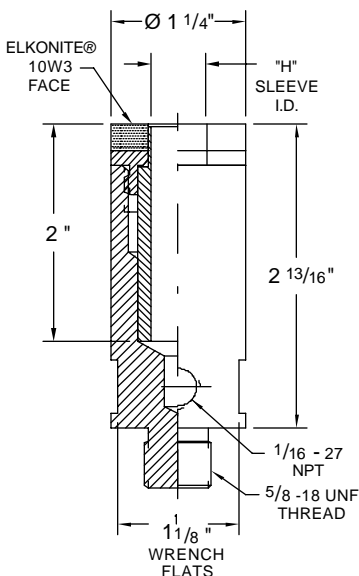

Stud Welding Assemblies	Screw Thread Size	"H"	CMW® 3 Base	Ceramic Coated Stainless Steel Sleeve	Elkonite® Faced Cap
16-37526-399	10MM	.399	16-37526	16-953399	16-37526-C399
16-37526-444	.438	.444	16-37526	16-953444	16-37526-C444
16-37526-477	12MM	.477	16-37526	16-953477	16-37526-C477
16-37526-502	.500	.502	16-37526	16-953502	16-37526-C502
16-37526-630	.625	.630	16-37526	16-953630	16-37526-C630

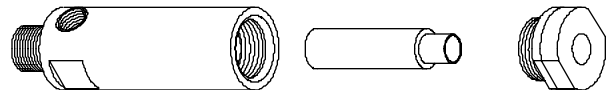

FOR 5/8" DIA. • USE COOLING CHAMBER 18-1340 P.24

FOR 1" DIA. • MAY BE USED WITH HOLDERS 18-169, 18-170, 18-171 P.29
 AND 1 1/4" DIA. • FOR USE WITH PLATEN MOUNTED HOLDERS USE ADAPTER 18-7743 P.27
 • HOLDERS WITH 5RW TAPERS USE ADAPTERS 18-7741, 18-7742 P.23
 • USE COOLING CHAMBERS 18-1342, 18-1343 P.24

SELF-PILOTING NUT WELDING ELECTRODES



NSRW Co., Inc. (800) 933-6779, FAX: (205) 663-3221 Authorized Distributor CMW Inc.

The shanks are CMW® 3. Facings are ELKONITE®

Note: locating pins are made of specially treated aluminum, having a surface hardness of approximately 55 Rockwell C on outside surface.

ASSEMBLED ELECTRODE See page 6 for Metric conversions See page 7 for Taper dimensions	Taper Size D	Pin Dia. "N"	For Nut Thread Size "N"	Pin Length "L"	Part No.	Typical Set-Up for Self Piloting Nuts
16-3764-XX 	5RW	.082	#4	.093	16-3764-04	
		.093	#5	.093	16-3764-05	
		.100	#6	.093	16-3764-06	
		.107	3.5 mm	.093	16-3764-M3-5	
		2MT	.123	4.0 mm	.156	16-3764-M4
	.129		#8	.156	16-3764-08	
	.143		#10	.156	16-3764-10	
	.156		5.0 mm	.156	16-3764-M5	
	16-3765-XX 	5RW	.166	#12	.375	16-3765-12
.189			6.0 mm	.375	16-3765-M6	
.192			1/4	.375	16-3765-25	
.223			7.0 mm	.375	16-3765-M7	
2MT			.252	8.0 mm	.375	16-3765-M8
		.257	5/16	.375	16-3765-31	
		.291	9.0 mm	.375	16-3765-M9	
16-3766-XX 		5RW	.306	3/8	.375	16-3766-38
	.320		10 mm	.375	16-3766-M10	
	.359		11 mm	.375	16-3766-M11	
	.361		7/16	.375	16-3766-44	
	2MT	.388	12 mm	.375	16-3766-M12	
		.415	1/2	.375	16-3766-50	
		.455	14 mm	.375	16-3766-M14	

NON-PILOTING NUT WELDING ELECTRODES



NSRW Co., Inc. (800) 933-6779, FAX: (205) 663-3221 Authorized Distributor CMW Inc.

The shanks are CMW® 3. Facings are ELKONITE®

Note: locating pins are made of specially treated aluminum, having a surface hardness of approximately 55 Rockwell C on outside surface.

ASSEMBLED ELECTRODE See page 6 for Metric conversions See page 7 for Taper dimensions	Taper or Thd. Size	Pin Dia. "N"	Pilot Length "L"	Pilot Dia. "P"	For Nut Thread Size "N"	Part No.
16-3774-XX 	5RW 2MT	.082	.312	.142	#4	16-3774-04
		.093	.312	.158	#5	16-3774-05
		.100	.312	.173	#6	16-3774-06
		.129	.312	.198	#8	16-3774-08
		.143	.312	.220	#10	16-3774-10
.186	.312	.250	6mm	16-3774-M6		
16-3775-XX 	5RW 2MT	.166	.312	.250	#12	16-3775-12
		.186	.312	.250	6 mm	16-3775-M6
		.192	.312	.283	1/4	16-3775-25
		.252	.312	.283	8 mm	16-3775-M8
		.257	.312	.345	5/16	16-3775-31
.322	.312	.347	10 mm	16-3775-M10		
16-3785-XX 	5/8-18	.166	.375	.250	#12	16-3785-12
	Thd.	.186	.375	.269	6 mm	16-3785-M6
		.192	.375	.283	1/4	16-3785-25
		.252	.375	.348	8 mm	16-3785-M8
		.257	.375	.345	5/16	16-3785-31
		.320	.375	.427	10 mm	16-3785-M10
		.359	.375	.466	11 mm	16-3785-M11
.388	.375	.470	12 mm	16-3785-M12		
16-3786-XX 	5/8-18	.166	.375	.250	#12	16-3786-12
	Thd.	.186	.375	.269	6 mm	16-3786-M6
		.192	.375	.283	1/4	16-3786-25
		.252	.375	.348	8 mm	16-3786-M8
		.257	.375	.345	5/16	16-3786-31
		.306	.375	.408	3/8	16-3786-38
		.320	.375	.427	10 mm	16-3786-M10
		.359	.375	.466	11 mm	16-3786-M11
		.361	.375	.470	7/16	16-3786-44
		.388	.375	.470	12 mm	16-3786-M12
		.415	.375	.533	1/2	16-3786-50

Typical Set-Up for Non Piloting Nuts

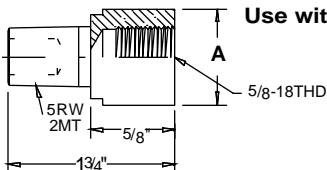
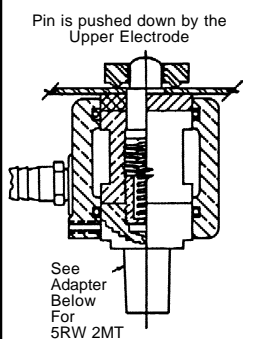
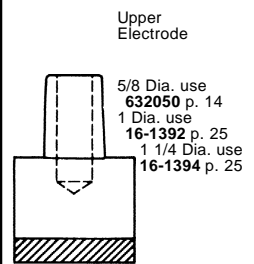

A	Part No.	Use With
1	18-7741	16-3785-XX
1 1/4	18-7742	16-3786-XX

Note: Electrode Assemblies 18-3785-XX and 18-3786-XX May also be used with 5/8-18 Thread Holders 18-169, 18-170 and 18-171 as shown on page 29.

STUD WELDING ELECTRODES

NSRW Co., Inc. (800) 933-6779, FAX: (205) 663-3221 Authorized Distributor CMW Inc.



Stud Welding Electrode facings are Elkonite® 10W3. The shank is CMW® 3.
 Note: insulation sleeves are made of specially treated aluminum having a surface hardness of approximately 55 Rockwell C on both I.D. and O.D.

ASSEMBLED ELECTRODE	*Screw Thread Size	Insulation		Part No. Assembled Electrode		
		I.D.	H.			
<p>See page 6 for Metric conversions See page 7 for Taper dimensions</p> <p>16-3724-XXXX</p>	#4	Depth B .116	.375 16-3724-1161	.750 16-3724-1162	1.125 16-3724-1163	
	#5	.132	16-3724-1321	16-3724-1322	16-3724-1323	
	#6	Depth B .140	.500 16-3724-1401	1.00 16-3724-1402	1.500 16-3724-1403	
	—	.150	16-3724-1501	16-3724-1502	16-3724-1503	
	—	.157	16-3724-1571	16-3724-1572	16-3724-1573	
	#8	.169	16-3724-1691	16-3724-1692	16-3724-1693	
	#10	Depth B .191	.750 16-3724-1911	1.500 16-3724-1912		
	#12	.220	16-3724-2201	16-3724-2202		
	.250	.254	16-3724-2541	16-3724-2542		
	<p>16-3725-XXXX</p>	.250	Depth B .254	.750 16-3725-2541	1.500 16-3725-2542	
—		Depth B .277	1.00 16-3725-2771	2.00 16-3725-2772		
.312		.317 (8mm)	16-3725-3171	16-3725-3172		
—		.339	16-3725-3391	16-3725-3392		
—		.365	16-3725-3651	16-3725-3652		
.375		.380	16-3725-3801	16-3725-3802		
<p>16-3726-XXXX</p>	—	Depth B .401	1.00 16-3726-4011	2.00 16-3726-4012		
	—	.427	16-3726-4271	16-3726-4272		
	.437	.444	16-3726-4441	16-3726-4442		
	.500	.502	16-3726-5021	16-3726-5022		
	—	Depth B .552	1.00 16-3726-5521	2.00 16-3726-5522		
	.625	.630	16-3726-6301	16-3726-6302		
	—	.676	16-3726-6761	16-3726-6762		
	—	.801	16-3726-8011	16-3726-8012		

For upper electrode use standard electrode:

- 5/8 Dia. 632050 page 14
- 1 Dia. 16-1392 page 25
- 1 1/4 Dia. 16-1394 page 25

- | | |
|--------------------|---------------------|
| For Stud Electrode | Use Cooling Chamber |
| 16-3724-XXXX | 18-1340 |
| 16-3725-XXXX | 18-1342 |
| 16-3726-XXXX | 18-1343 |
| See Above | See Above |

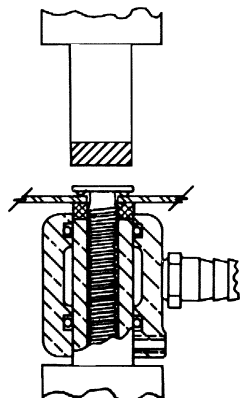

CMW External Water Cooling Chambers are designed to provide supplementary cooling in special, hard-to-cool applications. These cast aluminum jackets are securely sealed and locked in position over the external surface of 5/8", 7/8", 1", or 1 1/4" diameter electrodes. Standard water nipples connect to the regular water inlet and outlet hoses of these external cooling chambers.

CMW External Water Cooling Chambers are also recommended for *additional* cooling capacity on internally cooled applications operating at elevated temperatures.

One Piece Aluminum Castings—Rubber "O" Ring Seals—Standard Water Nipples—Allen Head Set-Screw Lock-On.

EXTERNAL ELECTRODE COOLING CHAMBERS

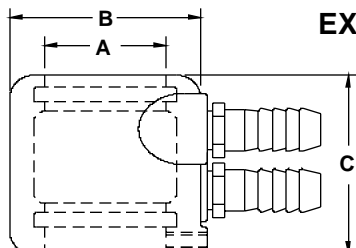

PART NO.	To Fit A Dia. Electrode	O.D. B	Overall Length C
18-1340	5/8	1 1/4	1 1/2
18-1341	7/8	1 1/2	1 1/2
18-1342	1	1 3/4	1 1/2
18-1343	1 1/4	2	1 7/8

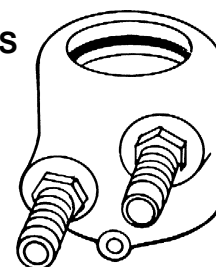

BACK-UP ELECTRODES

NSRW Co., Inc. (800) 933-6779, FAX: (205) 663-3221 Authorized Distributor CMW Inc.



SWIVEL HEAD BACK-UP ELECTRODES

Standard Material: Shank-CMW® 3, Cap-CMW® 3 optional material available on special order: Cap-CMW® 100; ELKONITE® and ELKON® facing.

See page 6 for Metric conversions	Type	Part No.	Taper D	Water Hole Dia. F	Face Dia. H	
	Thru Hole "O" Ring	16-2304	4RW 1MT	9/32	7/8	
		16-2305	5RW 2MT	3/8	1	
		16-2302	4RW 1MT	9/32	3/8	1
		16-2303	5RW 2MT	3/8	1-1/4	
	Blind Hole	16-2314	4RW 1MT	9/32	7/8	
		16-2315	5RW 2MT	3/8	1	
		16-2312	4RW 1MT	9/32	3/8	1-1/4
		16-2313	5RW 2MT	3/8	1-1/2	
	Blind Hole With Spring and Ball	16-23129	4RW 1MT	9/32	1	
		16-23139	5RW 2MT	3/8	1-1/4	
		16-23109	4RW 1MT	9/32	3/8	1-1/4
		16-23119	5RW 2MT	3/8	1-1/2	
	Blind Hole With Spring and Ball	16-23169	4RW 1MT	9/32	1-1/4	
		16-23179	5RW 2MT	3/8	1-1/2	

LARGE DIAMETER FLAT FACED BACK-UP ELECTRODES

See page 6 for Metric conversions	Part No.	Weld Face Material	Overall Length C	Taper D	Water Hole		Weld Face Dia. H	Shank Length T	
					Dia. F	Depth G			
	16-3012	CMW® 3	1-1/4	4RW or 1MT	9/32	7/8	3/4	5/8	
	16-3010	CMW® 3					1		
	16-3030	CMW® 3					1-1/4		
	16-3021	CMW® 3	1-1/2	5RW or 2MT	3/8	1-1/8	7/8	7/8	
	16-3020	CMW® 3					1		
	16-3040	CMW® 3					1-1/4		
	16-3050	CMW® 3					1-1/2		
	16-1392	ELKONITE® 10W3	2	5RW or 2MT	3/8	1-1/2	1	7/8	
	16-1393	ELKONITE® 10W3	3				5/8		
	16-1394	ELKONITE® 10W3	2				1-1/2		1-1/4
	16-1395	ELKONITE® 10W3	3-1/4				5/8		1-1/4

SQUARE AND RECTANGULAR FACED BACK-UP ELECTRODES

See page 6 For Metric Conversion

Electrodes of other tapers and alloys available upon application.

16-382158 CMW® 3 CASTING (4RW 1MT, 7/8, 1 5/8, 1 1/2, 1/2)
16-382160 CMW® 3 CASTING (5RW 2MT, 7/8, 1 5/8, 1 1/2, 1/2)
16-3111 CMW® 3 CASTING (4RW 1MT, 9/32, 7/8, 1 5/8, 5/8, 2)
16-3121 CMW® 3 CASTING (5RW 2MT, 3/8, 7/8, 1 5/8, 5/8, 2)
16-3110 CMW® 3 COLD FORMED (4RW 1MT, 9/32, 13/16, 1 1/2, 1/2)
16-3120 CMW® 3 COLD FORMED (5RW 2MT, 3/8, 7/8, 1 3/4, 5/8, 5/8)
16-384110 CMW® 3 COLD FORMED (5RW 2MT, 3/8, 7/8, 1 5/8, 15/16, 1/2)

ORDER BY CMW PART NUMBER ONLY

THREADED ELECTRODES

NSRW Co., Inc. (800) 933-6779, FAX: (205) 663-3221 Authorized Distributor CMW Inc.



See page 6 for Metric conversions

CMW®3 Female Threaded Electrodes

CMW® 3 Part No.	C Overall Length	D Thread	A Major Dia.	E Thread Depth	G Water Hole Depth	F Water Hole Dia.	Over Wrench Flats	K Wrench Flat Length	H Welding Face Dia.
336508	2	5/8-18	1	3/4	1 1/4	37/64	7/8	3/4	1
336510			1 1/4				3/4	1 1/4	
336512			1 1/2				7/8	1 1/2	
326508	2	5/8-18	1	3/4	1 1/4	37/64	7/8	3/4	3/8
326510			1 1/4				3/4	1 1/2	
326512			1 1/2				7/8	5/8	

FLAT

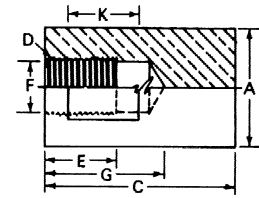

TRUNCATED

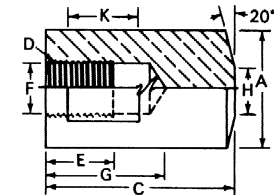

CMW®3 Male Threaded Electrodes

CMW® 3 Part No.	C Overall Length	D Thread	A Major Dia.	E Thread Depth	G Water Hole Depth	F Water Hole Dia.	Over Wrench Flats	K Wrench Flat Length	H Welding Face Dia.
330507	2	5/8-18	7/8	9/16	1 1/4	5/16	3/4	5/8	7/8
330508		5/8-18	1	9/16		5/16	7/8	5/8	1
335506		5/8-11	3/4	15/32		5/16	5/8	5/8	3/4
335507		5/8-11	7/8	15/32		5/16	3/4	3/4	7/8
335508	2	3/4-10	1	5/8	1 1/4	3/8	7/8	7/8	1
335510		3/4-10	1 1/4	5/8		3/8	1	3/4	1 1/4
335512		7/8-9	1 1/2	3/4		1/2	1 1/4	7/8	1 1/2
325506	2	5/8-11	3/4	15/32	1 1/4	5/16	5/8	1/2	1/4
325507		5/8-11	7/8	15/32		5/16	3/4	5/8	5/16
325508		3/4-10	1	5/8		3/8	7/8	5/8	3/8
325510		3/4-10	1 1/4	5/8		3/8	1	3/4	1/2

FLAT

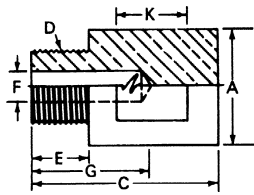

TRUNCATED

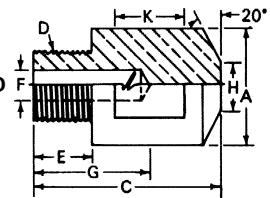

ELKONITE® Faced Female Threaded Electrodes

ELKONITE® 10W3 Part No.	C Overall Length	D Thread	A Major Dia.	E Thread Depth	G Water Hole Depth	F Water Hole Dia.	Over Wrench Flats	K Wrench Flat Length	H Welding Face Dia.	B ELKONITE Thickness
636308	1 1/2	5/8-18	1	3/4	1	37/64	7/8	1/2	1	1/4
636310			1 1/4				1/2	1 1/4		
636312			1 1/2				3/4	1 1/2		
626308	1 1/2	5/8-18	1	3/4	1	37/64	7/8	1/2	5/8	1/4
626310			1 1/4				1/2	1 1/2		

FLAT

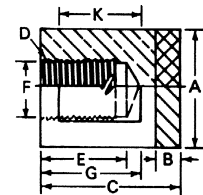

CENTERED

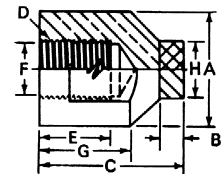

ELKONITE® Faced Male Threaded Electrodes

ELKONITE® 10W3 Part No.	C Overall Length	D Thread	A Major Dia.	E Thread Depth	G Water Hole Depth	F Water Hole Dia.	Over Wrench Flats	H Welding Face Dia.	B ELKONITE Thickness
620307	1 1/2	5/8-18	7/8	9/16	1	5/16	3/4	1/2	1/4
625206	1 1/4	5/8-11	3/4	15/32	7/8	5/16	5/8	1/2	3/16
625308	1 5/8	3/4-10	1	5/8	1 3/16	3/8	7/8	5/8	1/4

CENTERED

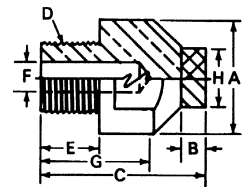

*Bodies for ELKONITE® Faced Electrodes are CMW® 3 Material

ADAPTERS

NSRW Co., Inc. (800) 933-6779, FAX: (205) 663-3221 Authorized Distributor CMW Inc.



MALE TAPER TO FEMALE TAPER ADAPTERS

ADAPTER PART NO.	MALE TAPER			FEMALE TAPER		Length Under Head M	Hex. Over Flats H	Overall Length C
	Size L	Minor Dia. J	Dia. @ 1/2" K	Size D	Major Dia. A			
18-741	5RW or 2MT	.588	.613	4RW or 1MT	.463	7/8	7/8	1 3/16
18-742	7RW or 3MT	.819	.844	5RW or 2MT	.613	1 3/16	1	1 1/2
18-7414	6RW	.706	.731	5RW	.613	7/8	1	1 3/16
18-7415	4RW or 1MT	.438	.463	5RW or 2MT	.613	5/8	7/8	1 3/4
18-7416	5RW or 2MT	.588	.613	6RW	.731	7/8	1	2 1/4

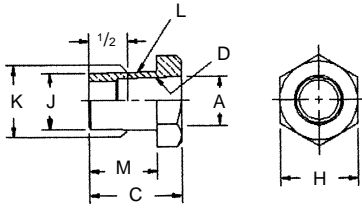

MALE PIPE THREAD TO FEMALE TAPER ADAPTERS

ADAPTER PART NO.	MALE THREAD Size L	FEMALE TAPER		Length Under Head M	Hex. Over Flats H	Overall Length C
		Size D	Major Dia. A			
18-746-07	1/2-14 pipe	4RW or 1MT	.463	5/8	1	7/8
18-747-07	1/2-14 pipe	5RW or 2MT	.613	5/8	1	7/8
18-7465-07	1/2-14 pipe	5RW MALE CAP	.414	9/16	7/8	7/8
18-748-06	5/8-14 pipe	4RW or 1MT	.463	9/16	1	3/4
18-749-06	5/8-14 pipe	5RW or 2MT	.613	9/16	1	3/4
18-756-09	3/4-14 pipe	4RW or 1MT	.463	7/8	1 1/4	1 1/8
18-757-09	3/4-14 pipe	5RW or 2MT	.613	7/8	1 1/4	1 1/8
18-7576-09	3/4-14 pipe	6RW	.731	7/8	1 1/4	1 1/8

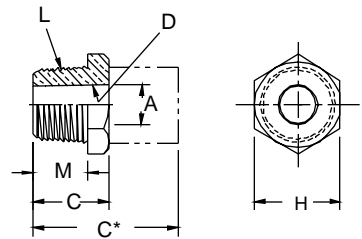

*Adapters of longer lengths available in 1/8" increments upon request

MALE THREAD TO FEMALE TAPER ADAPTERS

ADAPTER PART NO.	MALE THREAD Size L	FEMALE TAPER		Length Under Head M	Dia. Or Hex H	Overall Length C	Sealing Ring Part No.
		Size D	Major Dia. A				
18-750	5/8-18	4RW or 1MT	.463	9/16	7/8 Hex	13/16	18-10060-11
18-751	5/8-18	5RW or 2MT	.613	9/16	1 Hex	1 11/16	18-10060-11
*18-755	3/4-10	5RW or 2MT	.613	9/16	1 Dia.	1 9/16	18-10060-12
18-770	7/8-14	4RW or 1MT	.463	5/8	1 Hex	13/16	18-76460
18-771	7/8-14	5RW or 2MT	.613	5/8	1 Hex	13/16	18-76460
18-7743	1-14	5/8 - 18 THD	-	5/8	1 1/4 Hex	1	18-10060-17
18-785	1-14	4RW or 1MT	.463	9/16	1 1/4 Hex	13/16	18-10060-17
18-786	1-14	5RW or 2MT	.613	9/16	1 1/4 Hex	13/16	18-10060-17
18-7863	1-14	6RW	.731	3/4	1 1/4 Hex	1 3/4	18-10060-17
18-787	1-14	7RW or 3 MT	.844	3/4	1 1/4 Hex	2 1/8	18-10060-17
18-7875	1-14	5RW or 2MT	.613	9/16	1 1/4 Dia.	1 11/16	18-10060-17
18-7876	1-14	6RW	.731	5/8	1 1/4 Dia.	7/8	18-10060-17

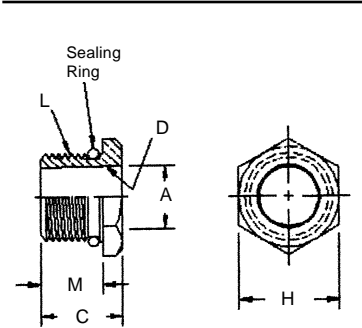

*This part has 3/4" wrench flats.

FEMALE THREAD TO FEMALE TAPER ADAPTERS

ADAPTER PART NO.	FEMALE THREAD Size L	FEMALE TAPER		Outside Dia. B	Over Wrench FLats H	Overall Length C
		Size D	Major Dia. A			
18-753	5/8-18	4RW or 1MT	.463	1	3/4	1 5/8
18-754	5/8-18	5RW or 2MT	.613	1	3/4	1 5/8
18-7591	3/4-10	4RW or 1MT	.463	1 1/4 Hex	1 1/4	1 3/4
18-7592	3/4-10	5RW or 2MT	.613	1 1/4 Hex	1 1/4	1 3/4

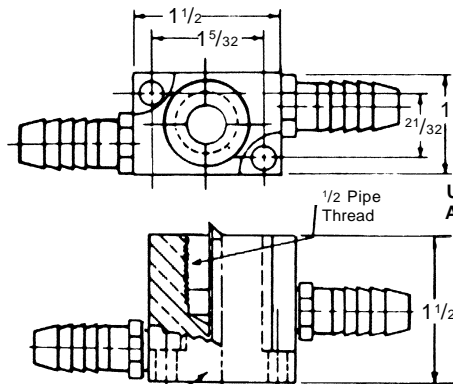
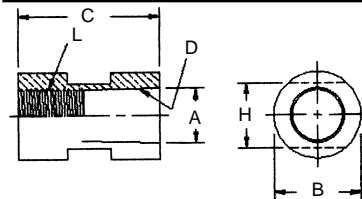

18-82650 ADAPTER ASSY 1/2 - 14 PIPE THD.

USE WITH 1/2 PIPE THREAD ADAPTERS LISTED ON THIS PAGE

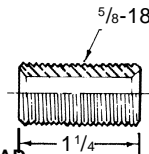

ADAPTER PART NO. 18-752

See page 6 for Metric conversions
See page 7 for Taper dimensions

See page 30 for Ejector type Adapters

ORDER BY CMW PART NUMBER ONLY

TYPICAL SET-UP COMBINATIONS USING CMW WELDING PRODUCTS

NSRW Co., Inc. (800) 933-6779, FAX: (205) 663-3221 Authorized Distributor CMW Inc.



COMBINATIONS OF CMW HOLDERS, ADAPTERS AND ELECTRODES CAN PERFORM MOST RESISTANCE WELDING APPLICATIONS

Many of these combinations make possible welding operations that could have been done heretofore only by the use of "expensive and special" holders and electrodes. A few ideas of the many possible combinations are shown for your guidance.

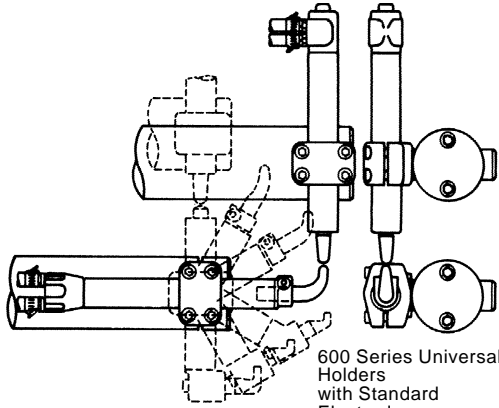

600 Series Universal Holders with Standard Electrodes

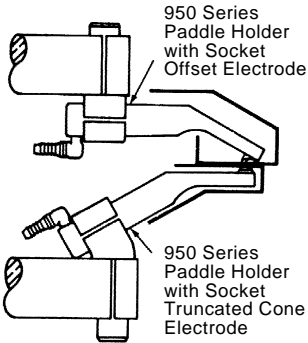

950 Series Paddle Holder with Socket Offset Electrode

950 Series Paddle Holder with Socket Truncated Cone Electrode

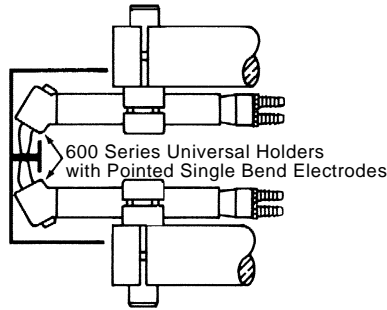

600 Series Universal Holders with Pointed Single Bend Electrodes

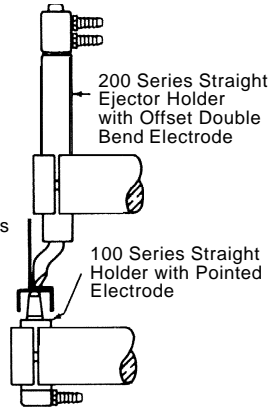

200 Series Straight Ejector Holder with Offset Double Bend Electrode

100 Series Straight Holder with Pointed Electrode

200 Series Straight Ejector Holder with Pointed Double Bend Electrode

500 Series Heavy Duty Holder with 30° Offset Electrode

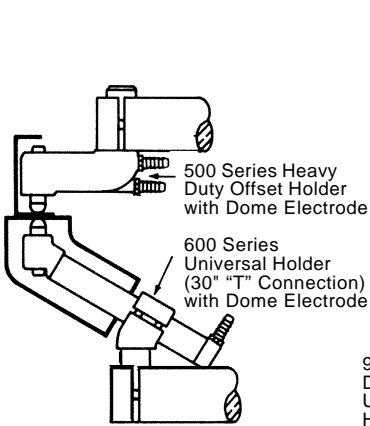

500 Series Heavy Duty Offset Holder with Dome Electrode

600 Series Universal Holder (30° "T" Connection) with Dome Electrode

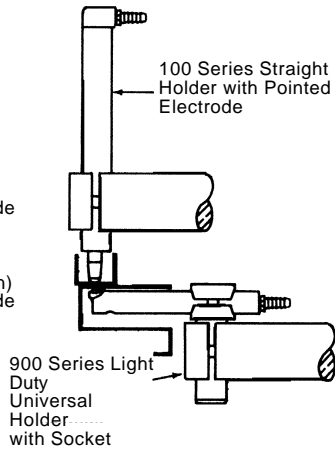

100 Series Straight Holder with Pointed Electrode

900 Series Light Duty Universal Holder with Socket

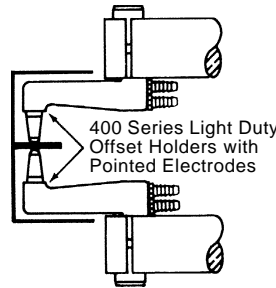

400 Series Light Duty Offset Holders with Pointed Electrodes

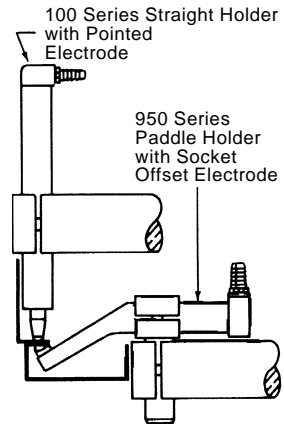

100 Series Straight Holder with Pointed Electrode

950 Series Paddle Holder with Socket Offset Electrode

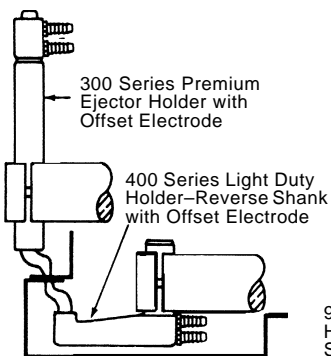

300 Series Premium Ejector Holder with Offset Electrode

400 Series Light Duty Holder-Reverse Shank with Offset Electrode

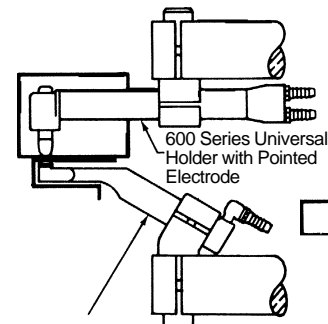

600 Series Universal Holder with Pointed Electrode

950 Series Paddle Holder with Socket Radius Electrode

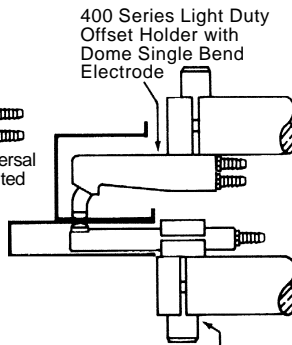

400 Series Light Duty Offset Holder with Dome Single Bend Electrode

900 Series Light Duty Universal Holder with Socket Radius Electrode

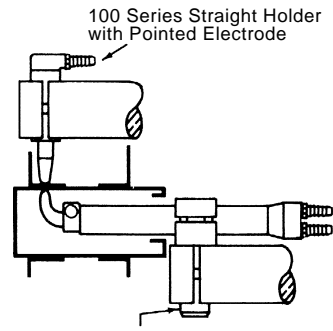

100 Series Straight Holder with Pointed Electrode

600 Series Universal Holder with Single Bend Electrode

100 SERIES (NON-EJECTOR) WATER COOLED ELECTRODE HOLDERS

NSRW Co., Inc. (800) 933-6779, FAX: (205) 663-3221 Authorized Distributor CMW Inc.

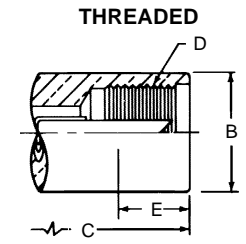
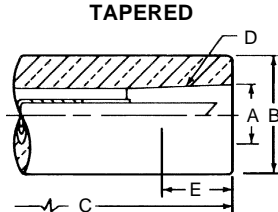
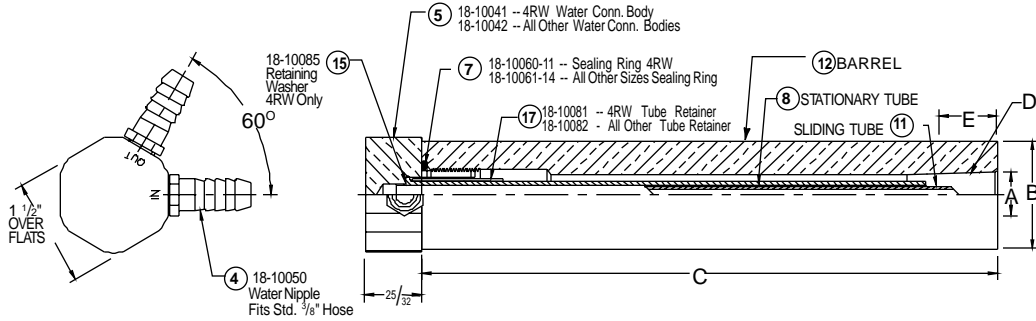

ADAPTERS FOR USE WITH THREADED

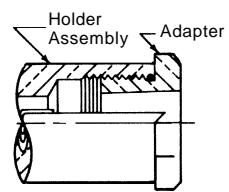

HOLDER ASSEMBLY PART NUMBER	HOLDER SIZE					Water Connection Head Sub-Assembly Include Parts: 4 5 7 8 15 17	⑧ Stationary Tube	⑪ Sliding Tube	⑫ Barrel
	A Major Taper Dia.	B Barrel Dia.	C Barrel Length	D Taper Or Thread	E Engagement with Std. Electrode				
18-101	.463	3/4	3	4RW	1/2	18-10091-3	18-10044-3	18-10046-3	18-11110-3
18-102		7/8		1MT					18-11210-3
18-103		1							18-11310-3
18-104		1 1/4							18-11410-3
18-106	.625	1	3	5RW	3/4	18-10092-3	18-10045-3	18-10047-3	18-11610-3
18-107		1 1/4		2MT					18-11710-3
18-108		1 1/2							18-11810-3
18-111	.463	3/4	8	4RW	1/2	18-10091-8	18-10044-8	18-10046-8	18-11110-8
18-112		7/8		1MT					18-11210-8
18-113		1							18-11310-8
18-114		1 1/4							18-11410-8
18-116	.625	1	8	5RW	3/4	18-10092-8	18-10045-8	18-10047-8	18-11610-8
18-117		1 1/4		2MT					18-11710-8
18-118		1 1/2							18-11810-8
18-119	.875	1 1/4	8	7RW	1 1/8	18-10092-8	18-10045-8	18-10047-8	18-11910-8
18-120		1 1/2		3MT					18-12010-8
18-131	.463	3/4	12	4RW	1/2	18-10091-12	18-10044-12	18-10046-8	18-11110-12
18-132		7/8		1MT					18-11210-12
18-133		1							18-11310-12
18-134		1 1/4							18-11410-12
18-136	.625	1	12	5RW	3/4	18-10092-12	18-10045-12	18-10047-8	18-11610-12
18-137		1 1/4		2MT					18-11710-12
18-138		1 1/2							18-11810-12
18-169	—	1	8	5/8-18	9/16	18-10092-8	18-10045-8	18-10047-8	18-16910-8
18-170		1 1/4							18-17010-8
18-171		1 1/2							18-17110-8
18-172	—	1	8	7/8-14	9/16	18-10092-8	18-10045-8	18-10047-8	18-17210-8
18-173		1 1/4							18-17310-8
18-174		1 1/2							18-17410-8
18-175	—	1 1/4	8	1-14	3/4	18-10092-8	18-10045-8	18-10047-8	18-17510-8
18-176		1 1/2							18-17610-8

Holder Assembly No.	Adapter Part No.	Page	Attachment Description
18-169 18-170 18-171	18-750	29	4RW 1MT Female
	18-751	27	5RW 2MT Female
	18-752	27	5/8-18 M. Thd.
	18-811	36	#1 Size "Nu-Twist" [®]
18-172 18-173 18-174	18-770	27	4RW 1MT Female
	18-771	27	5RW 2MT Female
May also be used with universal Adapters having 7/8-14 Male thread SEE PAGE 35			
18-175 18-176	18-785	27	4RW 1MT Female
	18-786	27	5RW 2MT Female
	18-7863	27	6RW Female
	18-787	27	7RW 3MT Female
	18-812	36	#2 Size "Nu-Twist" [®]
May also be used with universal Adapters having 1-14 Male thread SEE PAGE 35			

ORDER BY CMW PART NUMBER ONLY

200 SERIES (EJECTOR) WATER COOLED ELECTRODE HOLDERS

NSRW Co., Inc. (800) 933-6779, FAX: (205) 663-3221 Authorized Distributor CMW Inc. 7RW 3MT MORSE TAPER ASSY. Adapter 18-20033

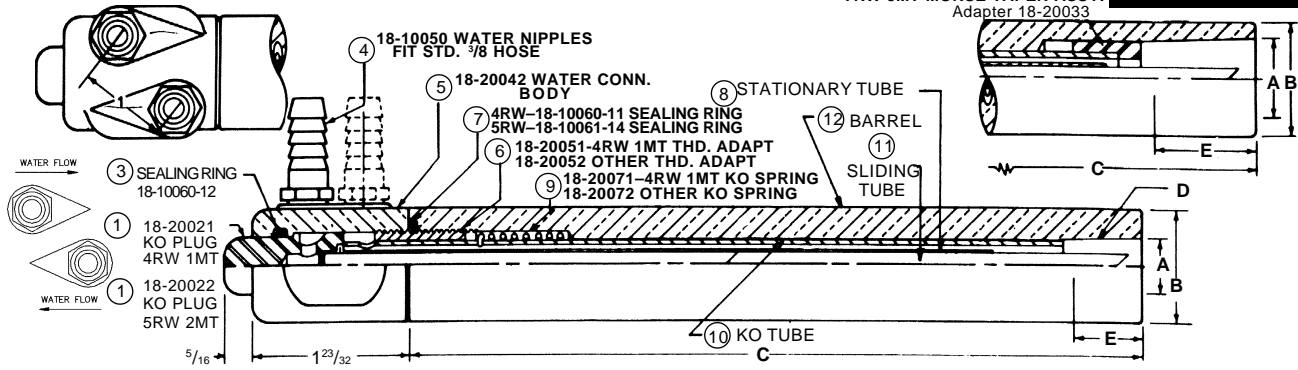

	HOLDER ASSEMBLY PART NUMBER	HOLDER SIZE					Water Conn. Hd. Sub-Assy. Include Parts: 1 3 4 5 6 7	KO Tube Sub-Assembly Include Parts: 8 9 10 11	⑧ Stationary Tube	⑩ KO Tube	⑪ Sliding Tube	⑫ Barrel
		A Major Taper Dia.	B Barrel Dia.	C Barrel Length	D Taper Or Thread	E Engrt. with Std. Elect.						
TAPERED 	18-201	.463	3/4	3	4RW	1/2	18-20091	18-20095-3	18-10044-3	18-20031-3	18-10046-3	18-11110-3 18-11210-3 18-11310-3 18-11410-3
	18-202	.463	7/8	3	4RW	1/2	18-20091	18-20095-3	18-10044-3	18-20031-3	18-10046-3	18-11110-3 18-11210-3 18-11310-3 18-11410-3
	18-203	.463	1	3	4RW	1/2	18-20091	18-20095-3	18-10044-3	18-20031-3	18-10046-3	18-11110-3 18-11210-3 18-11310-3 18-11410-3
	18-204	.463	1 1/4	3	4RW	1/2	18-20091	18-20095-3	18-10044-3	18-20031-3	18-10046-3	18-11110-3 18-11210-3 18-11310-3 18-11410-3
	18-206	.625	1	3	5RW	3/4	18-20092	18-20096-3	18-10045-3	18-20032-3	18-10047-3	18-11610-3 18-11710-3 18-11810-3
	18-207	.625	1 1/4	3	5RW	3/4	18-20092	18-20096-3	18-10045-3	18-20032-3	18-10047-3	18-11610-3 18-11710-3 18-11810-3
	18-208	.625	1 1/2	3	5RW	3/4	18-20092	18-20096-3	18-10045-3	18-20032-3	18-10047-3	18-11610-3 18-11710-3 18-11810-3
	18-211	.463	3/4	8	4RW	1/2	18-20091	18-20095-8	18-10044-8	18-20031-8	18-10046-8	18-11110-8 18-11210-8 18-11310-8 18-11410-8
	18-212	.463	7/8	8	4RW	1/2	18-20091	18-20095-8	18-10044-8	18-20031-8	18-10046-8	18-11110-8 18-11210-8 18-11310-8 18-11410-8
	18-213	.463	1	8	4RW	1/2	18-20091	18-20095-8	18-10044-8	18-20031-8	18-10046-8	18-11110-8 18-11210-8 18-11310-8 18-11410-8
	18-214	.463	1 1/4	8	4RW	1/2	18-20091	18-20095-8	18-10044-8	18-20031-8	18-10046-8	18-11110-8 18-11210-8 18-11310-8 18-11410-8
	THREADED 	18-216	.625	1	8	5RW	3/4	18-20092	18-20096-8	18-10045-8	18-20032-8	18-10047-8
18-217		.625	1 1/4	8	5RW	3/4	18-20092	18-20096-8	18-10045-8	18-20032-8	18-10047-8	18-11610-8 18-11710-8 18-11810-8
18-218		.625	1 1/2	8	5RW	3/4	18-20092	18-20096-8	18-10045-8	18-20032-8	18-10047-8	18-11610-8 18-11710-8 18-11810-8
18-219		.875	1 1/4	8	7RW	1 1/8	18-20092	18-20096-58	18-10045-8	18-20032-58 & 18-20033	18-10047-8	18-11910-8 18-12010-8
18-220		.875	1 1/2	8	7RW	1 1/8	18-20092	18-20096-58	18-10045-8	18-20032-58 & 18-20033	18-10047-8	18-11910-8 18-12010-8
18-231		.463	3/4	12	4RW	1/2	18-20091	18-20095-12	18-10044-12	18-20031-12	18-10046-8	18-11110-12 18-11210-12 18-11310-12 18-11410-12
18-232		.463	7/8	12	4RW	1/2	18-20091	18-20095-12	18-10044-12	18-20031-12	18-10046-8	18-11110-12 18-11210-12 18-11310-12 18-11410-12
18-233		.463	1	12	4RW	1/2	18-20091	18-20095-12	18-10044-12	18-20031-12	18-10046-8	18-11110-12 18-11210-12 18-11310-12 18-11410-12
18-234		.463	1 1/4	12	4RW	1/2	18-20091	18-20095-12	18-10044-12	18-20031-12	18-10046-8	18-11110-12 18-11210-12 18-11310-12 18-11410-12
18-236		.625	1	12	5RW	3/4	18-20092	18-20096-12	18-10045-12	18-20032-12	18-10047-8	18-11610-12 18-11710-12 18-11810-12
18-237		.625	1 1/4	12	5RW	3/4	18-20092	18-20096-12	18-10045-12	18-20032-12	18-10047-8	18-11610-12 18-11710-12 18-11810-12
18-238		.625	1 1/2	12	5RW	3/4	18-20092	18-20096-12	18-10045-12	18-20032-12	18-10047-8	18-11610-12 18-11710-12 18-11810-12
18-236-18		.625	1	18	5RW	3/4	18-20092	18-20096-18	18-10045-12	18-20032-18	18-10047-29	18-11610-18 18-11710-18 18-11810-18
18-237-18		.625	1 1/4	18	5RW	3/4	18-20092	18-20096-18	18-10045-12	18-20032-18	18-10047-29	18-11610-18 18-11710-18 18-11810-18
18-238-18	.625	1 1/2	18	5RW	3/4	18-20092	18-20096-18	18-10045-12	18-20032-18	18-10047-29	18-11610-18 18-11710-18 18-11810-18	
18-272	—	1	8	7/8-14	9/16	18-20092	18-20096-8	18-10045-8	18-20032-8	18-10047-8	18-17210-8 18-17310-8 18-17410-8	
18-273	—	1 1/4	8	7/8-14	9/16	18-20092	18-20096-8	18-10045-8	18-20032-8	18-10047-8	18-17210-8 18-17310-8 18-17410-8	
18-274	—	1 1/2	8	7/8-14	9/16	18-20092	18-20096-8	18-10045-8	18-20032-8	18-10047-8	18-17210-8 18-17310-8 18-17410-8	
18-275	—	1 1/4	8	1-14	3/4	18-20092	18-20096-8	18-10045-8	18-20032-8	18-10047-8	18-17510-8 18-17610-8	
18-276	—	1 1/2	8	1-14	3/4	18-20092	18-20096-8	18-10045-8	18-20032-8	18-10047-8	18-17510-8 18-17610-8	

EJECTOR TYPE ADAPTERS 7/8-14 THREAD

	ADAPTER PART NO.	MALE THREAD Size L	FEMALE TAPER		Length Under Head M	Hex Over Flats H	Overall Length C	Sealing Ring Part No.	KO Plug Part No.	
			Size D	Major Diameter A						
7/8-14 THREADED USE METALLIC SEAL KO PLUG 18-76460	18-7702	7/8-14	4RW 1MT	.463	5/8	1	13/16	18-76460	18-78501	
	18-7712	7/8-14	5RW 2MT	.625	1/2	1	1-1/16	18-76460	18-7712-3	
	Use With Threaded Ejector Holders to make Replaceable Taper Holders					Part No.		Description Threaded Holder		
						18-272		7/8-14 Fem. Thd. 1 Dia.		
					18-273		7/8-14 Fem. Thd. 1 1/4 Dia.			
					18-274		7/8-14 Fem. Thd. 1 1/2 Dia.			
EJECTOR TYPE ADAPTERS 1-14 THREAD										
1-14 THREADED "O" RING SEAL ADAPTER	18-7852	1-14	4RW 1MT	.463	9/16	1-1/4	13/16	18-10060-17	18-78501	
	18-7862	1-14	5RW 2MT	.625	7/16	1-1/4	1-1/16	18-10060-17	18-7712-3	
	18-7864	1-14	6RW	.750	3/4	1-1/4	1-3/4	18-10060-17	18-78650	
	18-7872	1-14	7RW 3MT	.875	3/4	1-1/4	2-1/8	18-10060-17	18-78701	
Use With Threaded Ejector Holders to make Replaceable Taper Holders					Part No.		Description Threaded Holder			
					18-275		1-14 Fem. Thd. 1 1/4 Dia.			
					18-276		1-14 Fem. Thd. 1 1/2 Dia.			

300 SERIES PREMIUM (EJECTOR) WATER COOLED ELECTRODE HOLDERS

NSRW Co., Inc. (800) 933-6779, FAX: (205) 663-3221 Authorized Distributor CMW Inc.



HOLDER BARRELS ARE CENTERLESS GROUND CMW®3 MATERIAL

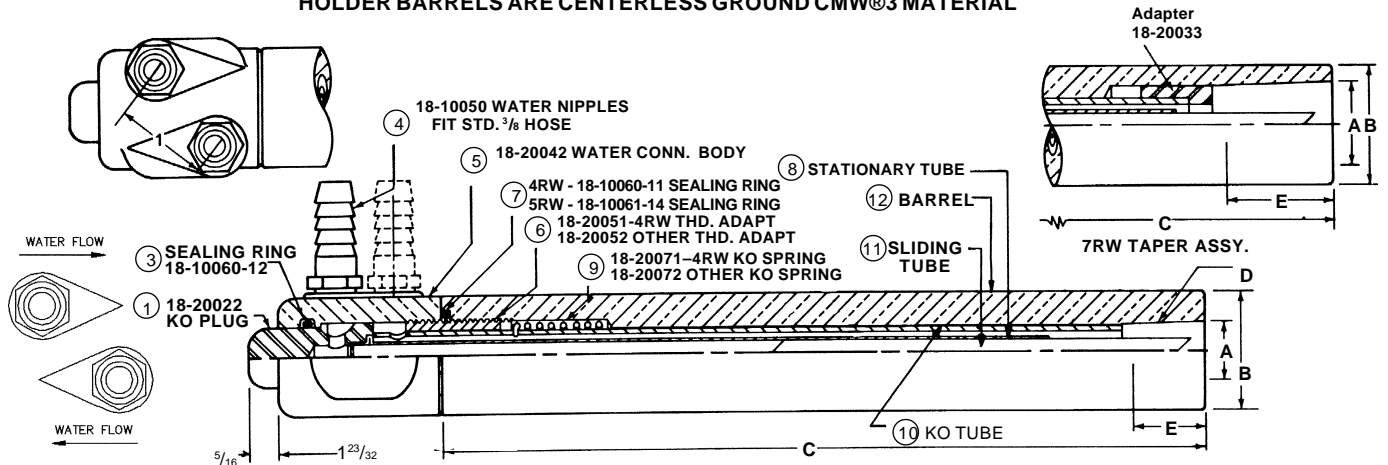

TAPERED SLIDING TUBE	HOLDER ASSEMBLY PART NUMBER	HOLDER SIZE					Water Conn. Hd. Sub-Assy. Include Pts. 1 3 4 5 6 7	KO Tube Sub-Assembly Include Parts: 8 9 10 11	⑧ Stationary Tube	⑩ KO Tube	⑪ Sliding Tube	⑫ Barrel
		A Major Taper Dia.	B Barrel Dia.	C Barrel Length	D Taper or Thread	E Engmt w/Std. Elect.						
	18-317		1 1/4		5RW							1831710-8
	18-318	.625	1 1/2	8	2MT	3/4	18-20092	18-20096-8	18-10045-8	18-20032-8	18-10047-8	1831910-8
	18-319		1 1/4		7RW							1831910-8
	18-320	.875	1 1/2	8	3MT	1 1/8	18-20092	18-20096-58	18-10045-8	18-20033	18-10047-8	1832010-8
	18-337		1 1/4		5RW							1831710-12
	18-338	.625	1 1/2	12	2MT	3/4	18-20092	18-20096-12	18-10045-12	18-20032-12	18-10047-8	1831810-12
	18-339		1 1/4		7RW							1831910-12
	18-340	.875	1 1/2	12	3MT	1 1/8	18-20092	18-20096-62	18-10045-12	& 18-20033	18-10047-8	1832010-12
	18-372		1									18-37210-8
	18-373	—	1/4	8	7/8-14	9/16	18-20092	18-20096-8	18-10045-8	18-20032-8	18-10047-8	18-37310-8
	18-375	—	1 1/4									18-37510-8
	18-376	—	1 1/2	8	1-14	3/4	18-20092	18-20096-8	18-10045-8	18-20032-8	18-10047-8	18-37610-8

Note: These threaded holder barrels same as on 600 Series holders page 34.

CMW PREMIUM HOLDER FEATURES

The CMW Premium Electrode Holder Barrels are made from high strength CMW® 3 material, centerless ground to within .002" tolerance on diameter and Nickel Plated to resist wear and assure uniform contact resistance of a low magnitude. These factors, in addition to the sturdy construction of the ejector mechanisms, plus the ample, well constructed water cooling passage, make these holders ideally suited for use with low frequency, direct current welders, and conventional alternating current machines using high weld currents.

To make replaceable Taper Holders use Adapters from tables at bottom of page 30

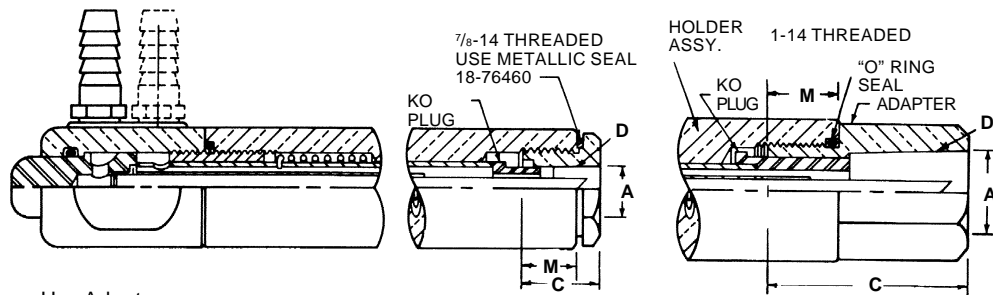

Use Adapters
 18-7702 4RW 1MT }
 18-7712 5RW 2MT }

with 7/8-14 thd'd. Holders

{ 18-372 1 Dia.
 18-373 1 1/4 Dia.

Use Adapters
 18-7852 4RW 1MT }
 18-7862 5RW 2MT }
 18-7864 6RW }
 18-7872 7RW 3MT }

with 1-14 thd'd. Holders

{ 18-375 1 1/4 Dia.
 18-376 1 1/2 Dia.

400 SERIES OFFSET (NON-EJECTOR) WATER COOLED ELECTRODE HOLDERS

NSRW Co., Inc. (800) 933-6779, FAX: (205) 663-3221 Authorized Distributor CMW Inc.

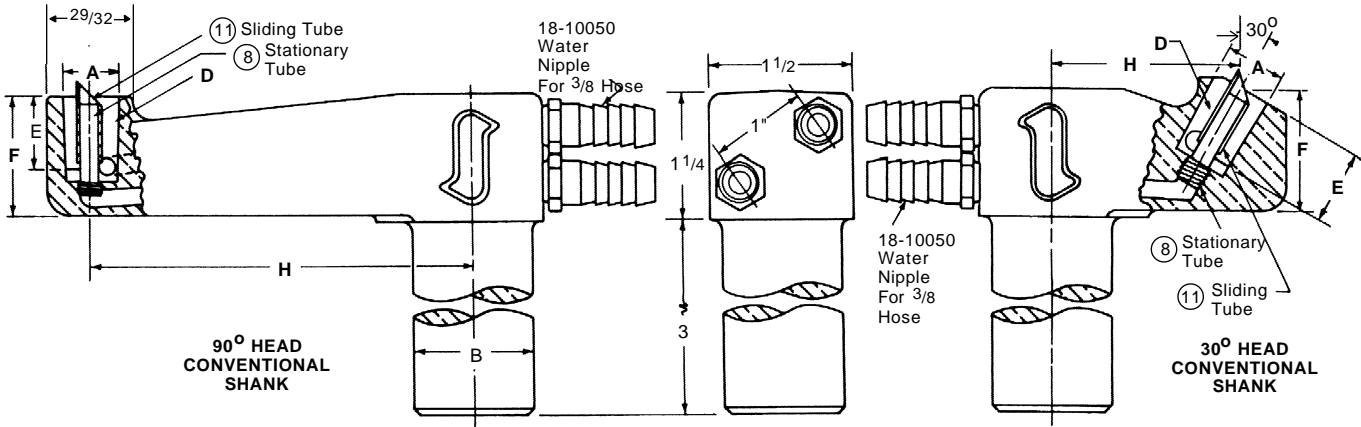

CONVENTIONAL SHANK

HOLDER ASSEMBLY NUMBER	Angle of Head	HOLDER SIZE						⑧ Stationary Tube	⑪ Sliding Tube	Angle of Head	HOLDER ASSEMBLY NUMBER
		A Major Taper Dia.	B Shank Dia.	D Taper	E Engagement with Std. Electrode	F Head Height	H Offset				
18-402 18-403 18-404	90°	.463	7/8 1 1-1/4	4RW 1MT	1/2	1-1/16	2	18-40041-1	18-40043-1	90°	_____
18-407 18-408 18-409	90°	.625	7/8 1 1-1/4	5RW 2MT	3/4	1-1/4	2	18-40041-1	18-40043-2	90°	_____
18-422 18-423 18-424	90°	.463	7/8 1 1-1/4	4RW 1MT	1/2	1-1/16	4	18-40041-1	18-40043-1	90°	18-433
18-428 18-429	90°	.625	1 1-1/4	5RW 2MT	3/4	1-1/4	4	18-40041-1	18-40043-2	90°	18-439
18-442 18-443 18-444	30°	.463	7/8 1 1-1/4	4RW 1MT	1/2	1	2	18-40041-1	18-40043-1	30°	_____
18-448 18-449	30°	.625	1 1-1/4	5RW 2MT	3/4	1-1/4	2	18-40041-1	18-40043-2	30°	_____
18-462 18-463 18-464	30°	.463	7/8 1 1-1/4	4RW 1MT	1/2	1	4	18-40041-1	18-40043-1	30°	_____
18-468 18-469	30°	.625	1 1-1/4	5RW 2MT	3/4	1-1/4	4	18-40041-1	18-40043-2	30°	_____

Holders of other shank diameters and lengths or tapers and with Reverse Shank are available on request.

REVERSE SHANK

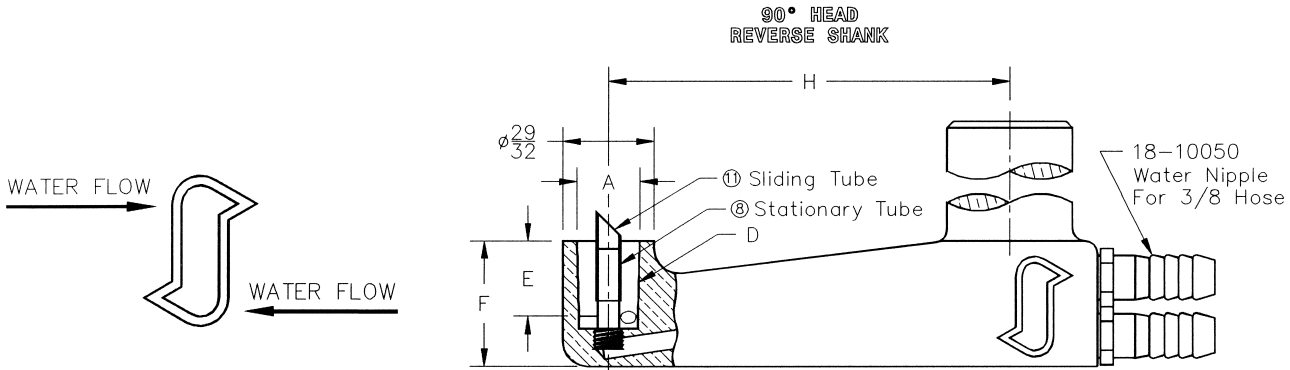

500 SERIES PREMIUM (EJECTOR) WATER COOLED OFFSET HOLDERS

NSRW Co., Inc. (800) 933-6779, FAX: (205) 663-3221 Authorized Distributor CMW Inc.

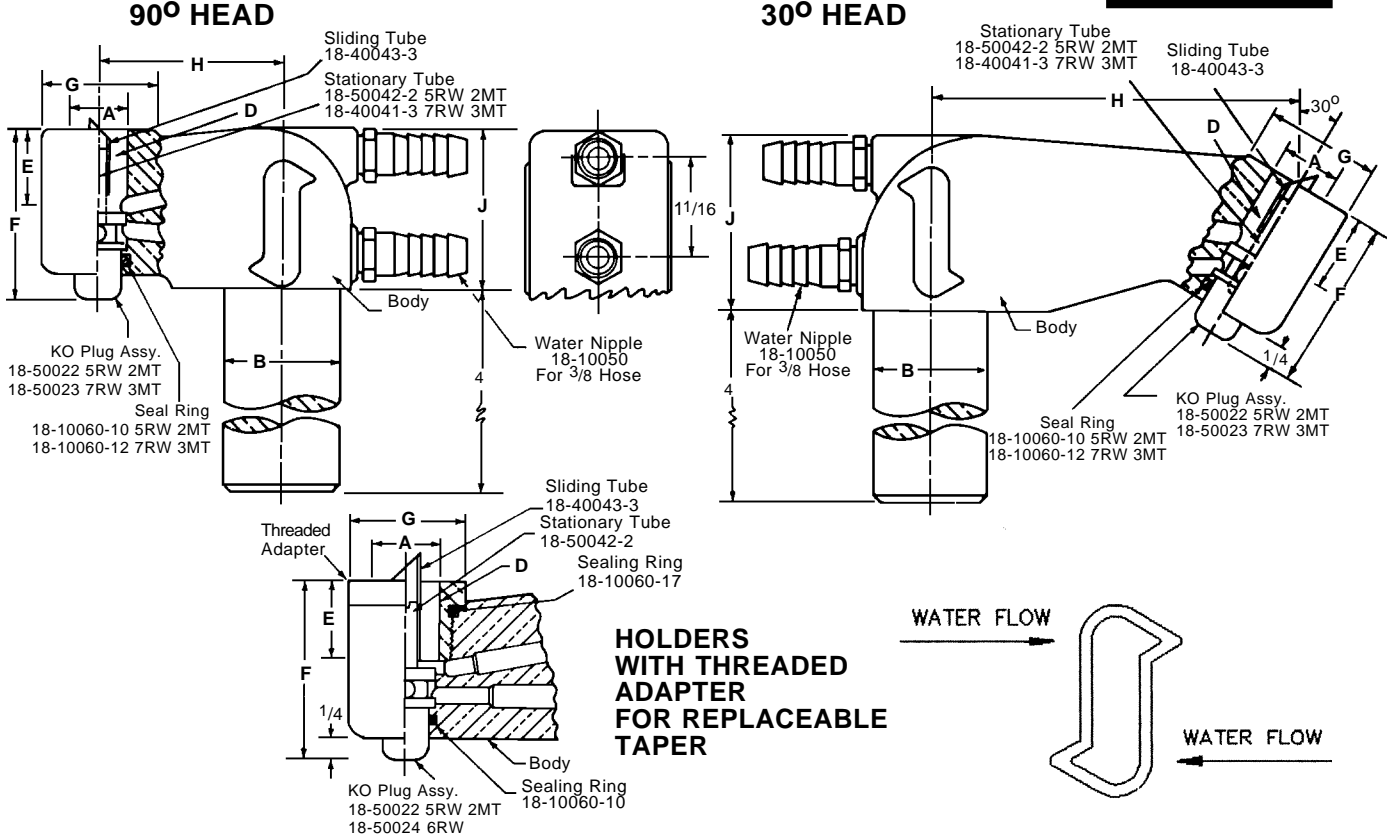

HOLDER ASSEMBLY NUMBER	Angle of Head	Major Taper Dia. A	Shank Dia. B	Taper D	Std. Taper Engagement E	Head Height F	Head Dia. G	C.L. Shank Offset H	Head Thickness J	Threaded Adapter Part No.
------------------------	---------------	--------------------	--------------	---------	-------------------------	---------------	-------------	---------------------	------------------	---------------------------

HOLDERS

18-502 18-503 18-504	90°	.625	1 1 1/4 1 1/2	5RW 2MT	3/4	1 13/16	1 1/4	2	1 23/32	_____
18-505 18-506	90°	.875	1 1/4 1 1/2	7RW 3MT	1 1/8	2 7/32	1 1/2	2	_____	_____
18-522 18-523 18-524	90°	.625	1 1 1/4 1 1/2	5RW 2MT	3/4	1 13/16	1 1/4	4	_____	_____
18-525 18-526	90°	.875	1 1/4 1 1/2	7RW 3MT	1 1/8	2 7/32	1 1/2	4	_____	_____
18-562 18-563 18-564	30°	.625	1 1 1/4 1 1/2	5RW 2MT	3/4	1 13/16	1 5/16	4	1 7/8	_____
18-565 18-566	30°	.875	1 1/4 1 1/2	7RW 3MT	1 1/8	2 7/32	1 9/16	4	_____	_____

HOLDERS WITH THREADED ADAPTER

18-5035 18-5036	90°	.625 .750	1 1/4	5RW 2MT 6RW	3/4 7/8	1 13/16 1 15/16	1 1/4	2	_____	18-7875 18-7876
18-5045 18-5046	90°	.625 .750	1 1/2	5RW 2MT 6RW	3/4 7/8	1 13/16 1 15/16	1 1/4	2	1 23/32	18-7875 18-7876
18-5235 18-5236	90°	.625 .750	1 1/4	5RW 2MT 6RW	3/4 7/8	1 13/16 1 15/16	1 1/4	4	_____	18-7875 18-7876
18-5245 18-5246	90°	.625 .750	1 1/2	5RW 2MT 6RW	3/4 7/8	1 13/16 1 15/16	1 1/4	4	_____	18-7875 18-7876
18-5635 18-5636	30°	.625 .750	1 1/4	5RW 2MT 6RW	3/4 7/8	1 13/16 1 15/16	1 1/4	4	1 7/8	18-7875 18-7876
18-5645 18-5646	30°	.625 .750	1 1/2	5RW 2MT 6RW	3/4 7/8	1 13/16 1 15/16	1 1/4	4	_____	18-7875 18-7876

ORDER BY CMW PART NUMBER ONLY

600 SERIES UNIVERSAL WATER COOLED ELECTRODE HOLDERS



NSRW Co., Inc. (800) 933-6779, FAX: (205) 663-3221 Authorized Distributor CMW Inc.

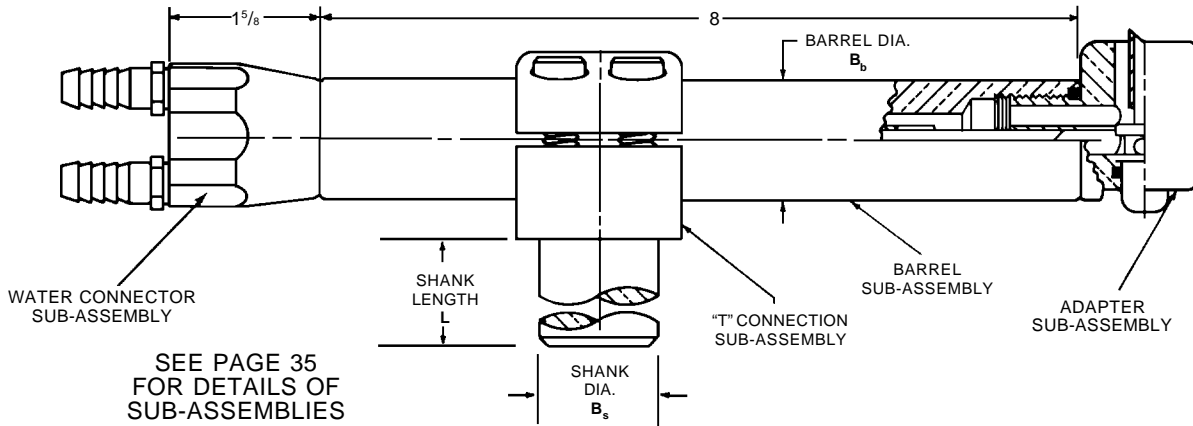

Part No.	Head Angle	Bbl. Dia. B _b	Shank Dia. B _s	Shank Length L	Head Assy.	Bbl. Assy.	"T" Conn. Assy.
----------	------------	--------------------------	---------------------------	----------------	------------	------------	-----------------

4RW 1MT

18-601	90°				18-764		
18-602	30°	1	7/8	3	18-765		18-725
18-603	90°				18-764	18-701	
18-604	30°	1	1	3	18-765		18-726
18-605	90°				18-764		
18-606	30°	1 1/4	1 1/4	3 1/2	18-765		18-727
18-607	90°				18-764	18-702	
18-608	30°	1 1/4	1 1/2	4	18-765		18-730

5RW 2MT

18-611	90°				18-766		
18-612	30°	1	7/8	3	18-767		18-725
18-613	90°				18-766	18-701	
18-614	30°	1	1	3	18-767		18-726
18-615	90°				18-766		
18-616	30°	1 1/4	1 1/4	3 1/2	18-767		18-727
18-617	90°				18-766	18-702	
18-618	30°	1 1/4	1 1/2	4	18-767		18-730
18-621	Str.	1	7/8			18-701	18-725
18-622	Str.	1	1	3			18-726
18-623	Str.	1 1/4	1 1/4	3 1/2	18-768		18-727
18-624	Str.	1 1/4	1 1/2	4		18-702	18-730
18-651	90°				18-780		
18-652	30°	1 1/4	1 1/4	3 1/2	18-781		18-727
18-657	90°				18-780	18-704	
18-658	30°	1 1/4	1 1/2	4	18-781		18-730

Part No.	Head Angle	Bbl. Dia. B _b	Shank Dia. B _s	Shank Length L	Head Assy.	Bbl. Assy.	"T" Conn. Assy.
----------	------------	--------------------------	---------------------------	----------------	------------	------------	-----------------

5RW 2MT

18-655	90°				18-780		
18-656	30°	1 1/2	1 1/4	4	18-781	18-705	18-728
18-653	90°				18-780		
18-654	30°	1 1/2	1 1/2	4	18-781	18-705	18-729
18-671	Str.	1 1/4	1 1/4	3 1/2		18-704	18-727
18-672	Str.	1 1/2	1 1/2	4		18-705	18-729
18-673	Str.	1 1/2	1 1/4		18-784	18-705	18-728
18-674	Str.	1 1/4	1 1/2	4		18-704	18-730

5RW 2MT with Threaded Adapter

18-6515	90°				18-7805		
18-6525	30°	1 1/4	1 1/4	3 1/2	18-7815	18-704	18-727
18-6535	90°				18-7805		
18-6545	30°	1 1/2	1 1/2	4	18-7815	18-705	18-729

6RW with Threaded Adapter

18-6516	90°				18-7806		
18-6526	30°	1 1/4	1 1/4	3 1/2	18-7816	18-704	18-727
18-6536	90°				18-7806		
18-6546	30°	1 1/2	1 1/2	4	18-7816	18-705	18-729

7RW 3MT

18-661	90°				18-782		
18-662	30°	1 1/4	1 1/4	3 1/2	18-783	18-704	18-727
18-665	90°				18-782		
18-666	30°	1 1/2	1 1/4	4	18-783	18-705	18-728
18-663	90°				18-782		
18-664	30°	1 1/2	1 1/2	4	18-783	18-705	18-729

BARREL SUB. ASSY.	BARREL PART NO.	WATER CONNECT. SUB ASSY.
18-701	18-37210-8	
18-702	18-37310-8	
18-704	18-37510-8	18-74000-8
18-705	18-37610-8	

600 SERIES UNIVERSAL HOLDER COMPONENTS

NSRW Co., Inc. (800) 933-6779, FAX: (205) 663-3221 Authorized Distributor CMW Inc.



SUB-ASSEMBLIES AND PARTS

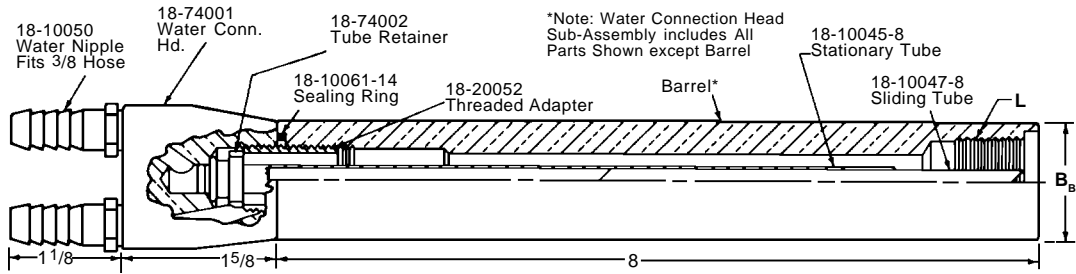

UNIVERSAL BARREL (HOLDER) SUB-ASSEMBLY NO.	L Thread Size	B _B Barrel Dia.	Barrel Part No.*	Water Conn.* Sub-Assembly Part No.
18-701		1	18-37210-8	
18-702	7/8-14	1 1/4	18-37310-8	18-74000-8
18-704		1 1/4	18-37510-8	
18-705	1-14	1 1/2	18-37610-8	18-74000-8

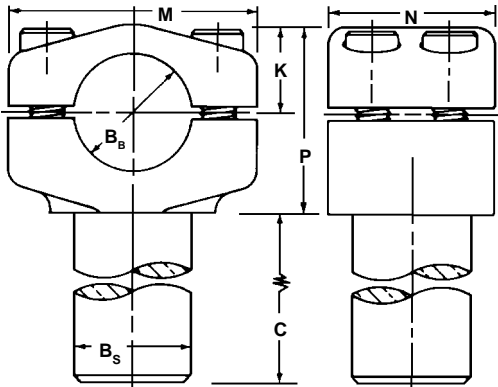

"T" CONNECTORS FOR HOLDERS

"T" CONNECTOR ASSEMBLY NO.	B _B Hole Dia.	B _S Shank Dia.	C Shank Length	P Head Height	K ØHole Over Top	M Length	N Width	
18-725	1	7/8	3	1 3/4	3/4	2 5/16	1 1/2	2 BOLT
18-726	1	1	3	1 3/4	3/4	2 5/16	1 1/2	
18-727	1 1/4	1 1/4	3 1/2	2	15/16	2 5/8	1 3/4	4 BOLT
18-728	1 1/2	1 1/4	4	2 5/16	1 1/8	2 7/8	2	
18-729	1 1/2	1 1/2	4	2 5/16	1 1/8	2 7/8	2	
18-730	1 1/4	1 1/2	4	2 5/16	1 1/8	2 7/8	2	

Note: See Page 42 for 30° and small 90° "T" connections.

MALE THREAD TO FEMALE TAPER ADAPTERS

90° TYPE

ADAPT WITH INSERT

30° TYPE

STRAIGHT TYPE

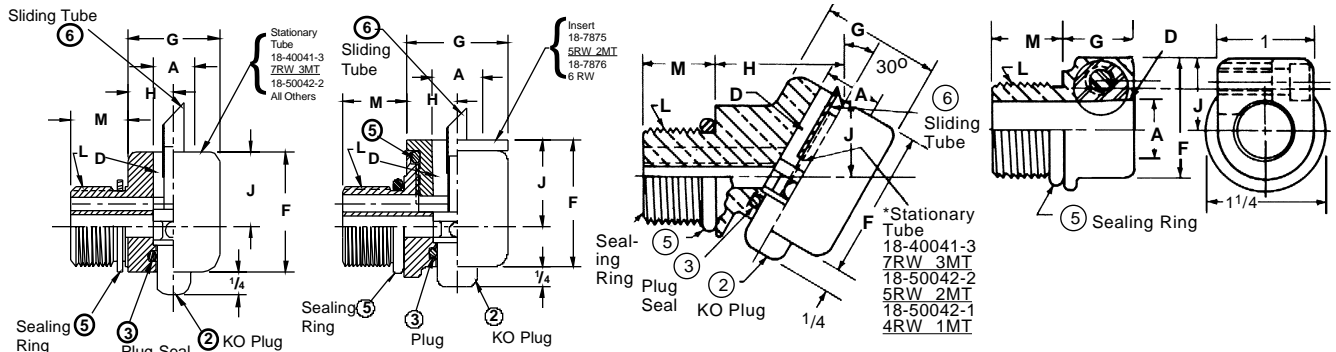

ASSEMBLY PART NO.	Adapter Angle	MALE THREAD		FEMALE TAPER		F Overall Head Height	G Head Length	H End B'bl. to C.L. of Taper	J C.L. Barrel to C.L. of Taper	② K.O. Plug Part No.	③ K.O. Plug Seal Part No.	⑤ Sealing Ring Part No.	⑥ Sliding Tube Part No.
		L Size Thd.	M Length	D Size	A Major Dia.								
18-764	90°			4RW				19/32	13/16				
18-765	30°	7/8-14	9/16	1MT	.463	19/16	1 Dia.	11/16	15/32	18-50021	18-10060-8	18-76460	18-50041-1
18-766	90°					113/16	1 Dia.	19/32	11/16	18-50022			18-40043-3
18-767	30°	7/8-14	9/16	5RW	.625	113/16	11/16 Dia.	11/32	53/64	18-50022	18-10060-10	18-76460	18-40043-3
18-768	Str.			2MT		1 1/4	3/4	—	3/4	—	—	—	—
18-780	90°					113/16	1 1/4 Dia.	21/32	11/16	18-50022			18-40043-3
18-781	30°	1-14	3/4	5RW	.625	113/16	15/16 Dia.	13/8	13/16	18-50022	18-10060-10	18-10060-17	18-40043-3
18-784	Str.			2MT		1 1/4	3/4	—	3/4	—	—	—	—
18-782	90°			7RW		113/16	1 1/2 Dia.	25/32	13/16				18-40043-4
18-783	30°	1-14	3/4	3MT	.875	23/16	19/16 Dia.	13/8	13/16	18-50023	18-10060-12	18-10060-17	18-40043-4
*18-7805	90°			5RW		113/16	1 1/4 Dia.	21/32	11/16				18-40043-3
*18-7815	30°	1-14	3/4	2MT	.625	113/16	15/16 Dia.	13/8	13/16	18-50022	18-10060-10	18-10060-17	18-40043-3
*18-7806	90°					113/16	1 1/4 Dia.	21/32	13/16				18-40043-3
*18-7816	30°	1-14	3/4	6RW	.750	115/16	15/16 Dia.	17/16	59/64	18-50022	18-10060-10	18-10060-17	18-40043-3

* These adapters have threaded inserts 18-7875—5RW 2MT or 18-7876—#6 RW Taper.

ORDER BY CMW PART NUMBER ONLY

800 SERIES "Nu-Twist"® ADAPTERS



NSRW Co., Inc. (800) 933-6779, FAX: (205) 663-3221 Authorized Distributor CMW Inc.

MAKE JOB CHANGES QUICKLY AND EASILY—WITHOUT COSTLY LOSS OF PRODUCTION

CMW "Nu-Twist"® FEATURES

1. The hex locking nut may be tightened or loosened effectively by hand or wrench for easy replacement of electrodes.
2. "O" ring seals provide water tight connections.
3. Double groove construction in bore or locking nut accurately aligns and locks the electrode in position with a maximum of a turn and one half.
4. Through use of baffles in adapters and in electrodes over 1" long efficient cooling is effectively achieved.
5. All components are of corrosion-resistant alloys.
6. Maintenance costs are unusually low.

NUMBER 1 SIZE

NUMBER 2 and 4 SIZES

SURFACE MOUNTED ADAPTERS

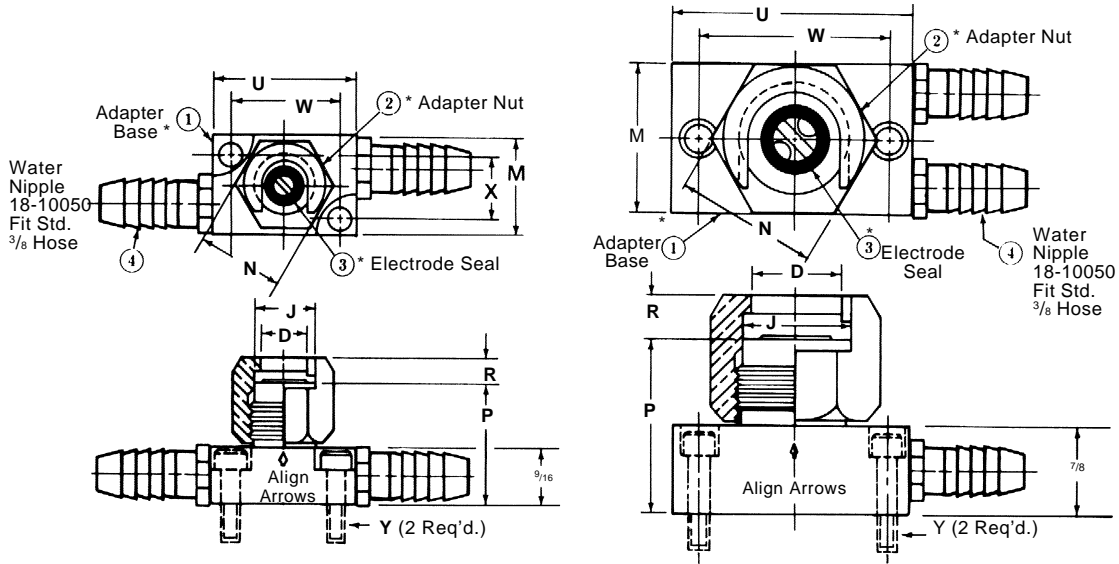

THREADED ADAPTERS

May be used with 100-200 and 300 Series Holders to make "Nu-Twist"® Holder.

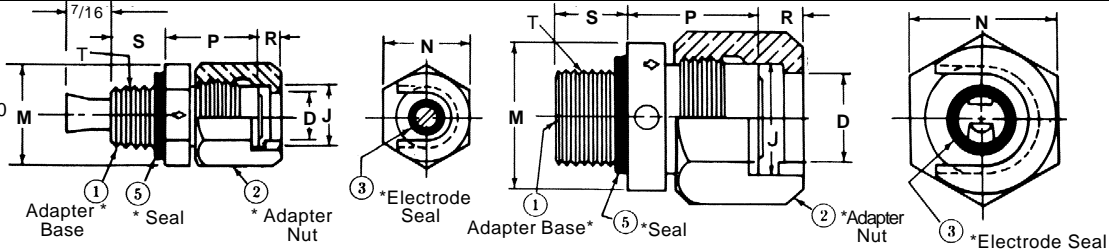

ADAPTER BASES ARE CMW® 3 MATERIAL

ADAPTER ASSEMBLY NUMBER	ADAPTER SIZE													① Adapter Base	② Adapter Nut	③ Electrode Seal	⑤ Seal	
	Surface Mounted	Threaded	D	J	M	N	P	R	S	T	U	W	X					Y
1 18-801	—	1/2	5/8	1	7/8	1 1/4	—	—	—	1 1/2	1 5/32	2 1/32	—	No. 10-24 Scr.	18-80110	18-80150	18-10060-5	—
—	18-811	15/16	1 1/8	1 1/2	1 1/2	1 5/16	7/16	3/4	1-14	2 1/2	2	—	—	No. 1/4-20 Scr.	18-80210	18-80250	18-10060-1	—
2 18-802	—	1 7/16	1 5/8	2	2	1 13/16	—	—	—	3	2 3/8	—	—	No. 1/4-20 Scr.	18-80410	18-80450	18-10061-10	18-10060-17
—	18-812	1 1/2	1 3/4	2 1/4	2 1/2	1 5/8	—	—	—	—	—	—	—	—	18-81210	—	18-10061-14	—
4 18-804	—	1 1/2	1 3/4	2 1/4	2 1/2	1 5/8	—	—	—	—	—	—	—	—	18-81410	—	—	—
—	18-814	1 1/2	1 3/4	2 1/4	2 1/2	1 5/8	—	—	—	—	—	—	—	—	—	—	—	18-10060-25

"Nu-Twist"® • Holders are available by combining Adapter 18-811 or 18-812 with holders shown on pages 29, 30 and 31
Non-Stock Holder Designs are available for use with 18-814.

MOUNTING INFORMATION FOR THREADED ADAPTERS

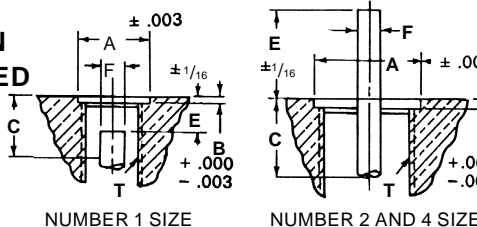

SIZE	THREADED ADAPTER ASSEMBLY NO.	A Dia. ±.003	B +.000 -0.003	C Min.	E ±1/16	F Dia.	T
1	18-811	.750	.083	5/8	3/8	.244	5/8-18
2	18-812	1.126	.113	13/16	15/16	.244	1-14
4	18-814	1.626	.173	13/16	15/16	.375	1 1/2-12

Adapters of other sizes are available on request.

SOCKET (OR BUTTON) AND "Nu-Twist"® ELECTRODES

NSRW Co., Inc. (800) 933-6779, FAX: (205) 663-3221 Authorized Distributor CMW Inc.



Socket Type CMW® 28, CMW® 3 and CMW® 100 Welding Electrodes

(Use with 900 and 950 Series Holders Page 42)

CMW® 28 18-970 CMW® 3 18-980 CMW® 100 18-990	CMW® 28 18-971 CMW® 3 18-981 CMW® 100 18-991	CMW® 28 18-972 CMW® 3 18-982 CMW® 100 18-992	CMW® 28 18-973 CMW® 3 18-983 CMW® 100 18-993	CMW® 28 18-974 CMW® 3 18-984 CMW® 100 18-994
FLAT FACE	TRUNCATED FACE	RADIUS FACE	OFFSET FACE	30° OFFSET FACE

"Nu-Twist"®, CMW® 3 and CMW® 100 Welding Electrodes

(Use with 800 Series Adapters Page 36, 38, 39)

No tapers or threads

Can be extracted with a simple turn of hexagon locking nut

Any contour in electrode face can be located or relocated in a given position

Water circulated to end of electrode for maximum cooling

Silver plated contact surfaces on electrode and base for maximum conductivity

Provides a simple, low-cost electrode for most special applications

Electrodes shown can be modified with contours to provide faces required

for most resistance welding applications

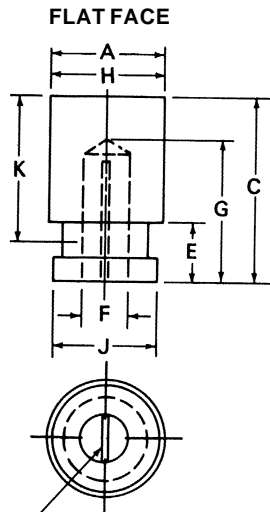
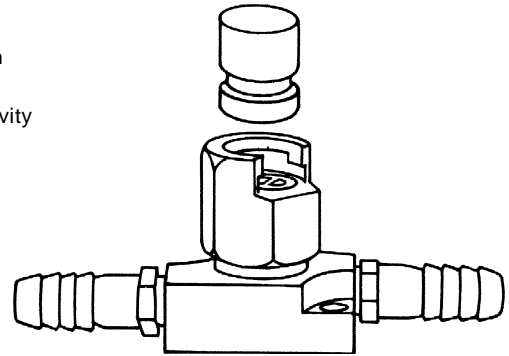

*This baffle is used in electrodes over 1" long to assure water circulation

"Nu-Twist"® ELECTRODES

Size	Type	ELECTRODE PART NO.		H Body Dia.	A Welding Face Dia.	C Overall Length	E Adapter Clearance	F Water Hole Dia.	G Water Hole Depth	J Electrode Seat Dia.	K Electrode Ext. From Adapt.
		CMW® 3	CMW® 100								
1	0 Flat	338750	538750	1/2	1/2	3/4	—	1/4	3/8	.625	1/2
		338030	538030	1/2	1/2	1 1/2	—	1/4	1 1/8	.625	1 1/4
1	0 Trunc.	378750	578750	1/2	1/4	3/4	—	1/4	3/8	.625	1/2
		378030	578030	1/2	1/4	1 1/2	—	1/4	1 1/8	.625	1 1/4
1	Flat	338751	538751	5/8	5/8	3/4	5/16	1/4	3/8	.625	1/2
		338031	538031	5/8	5/8	1 1/2	5/16	1/4	1 1/8	.625	1 1/4
2	Flat	338012	538012	1 1/4	1 1/4	1	5/8	1/2	1/2	1.125	1/2
		338052	538052	1 1/4	1 1/4	2	5/8	1/2	1 1/2	1.125	1 1/2
4	Flat	338014	538014	1 3/4	1 3/4	1	5/8	3/4	1/2	1.625	1/2
		338054	538054	1 3/4	1 3/4	2	5/8	3/4	1 1/2	1.625	1 1/2

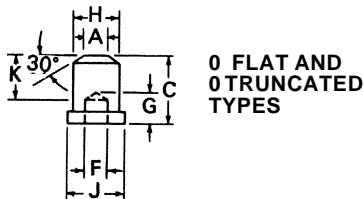

Where the above electrodes will not meet your special welding applications, consult your CMW distributor or factory for the assistance of CMW engineers in designing special electrodes for your application. The design may require special face contours, lengths or insulated locating pins. The specials feature the same advantages offered in all "Nu-Twist"® electrodes. To expedite this service where possible, specify electrode size, type, material, "H" diameter, "A" diameter (or face contour), "C" length, and "G" water hole depth. If job is very special, prints or samples of parts to be welded would be desirable.

ORDER BY CMW PART NUMBER ONLY

HYDRAULIC EQUALIZING ADAPTERS AND ASSEMBLIES

NSRW Co., Inc. (800) 933-6779, FAX: (205) 663-3221 Authorized Distributor CMW Inc.



CMW-Hydraulic Equalizing Adapter units are used to equalize the weld force when two or more welds are required simultaneously. The equalizing action is developed in a closed hydraulic system—and is accomplished by hydraulically interconnecting two or more units.

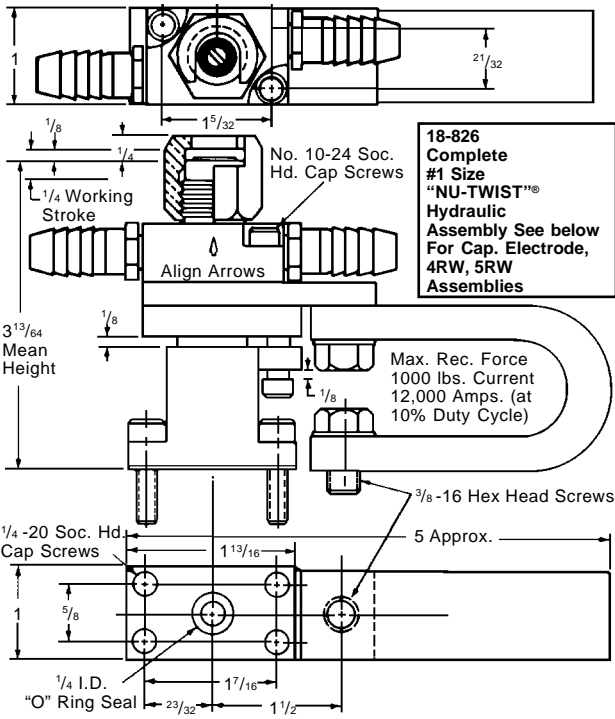

- 18-82651 Compl. #1 Size Hydr. Assy. for 5RW Male Cap
- 18-82652 Compl. #1 Size Hydr. Assy. 4RW 1MT
- 18-82653 Compl. #1 Size Hydr. Assy. 5RW 2MT

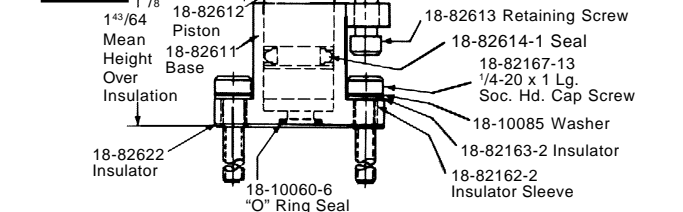
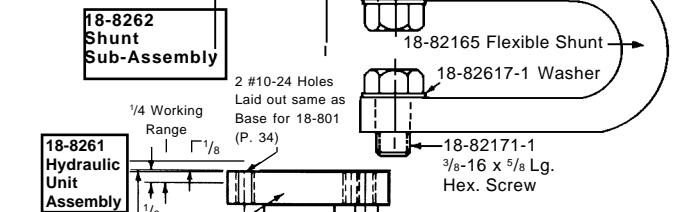
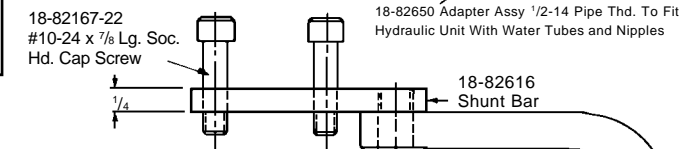
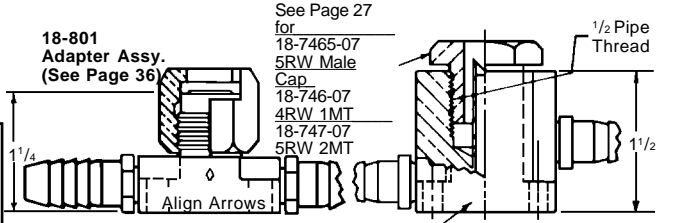

We recommend using a Fire Resistant Hydraulic Fluid compatible with BUNA "N" such as HOUGHTON-SAFE #620, 1120 or equivalent.

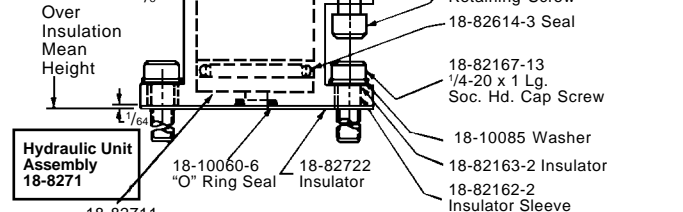
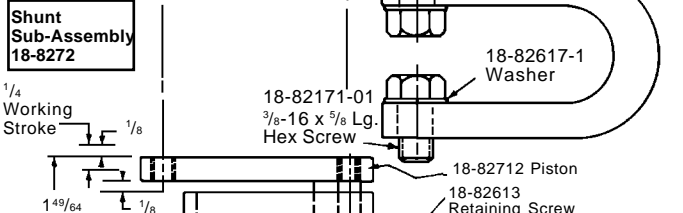
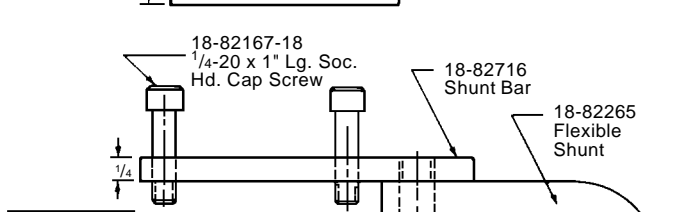
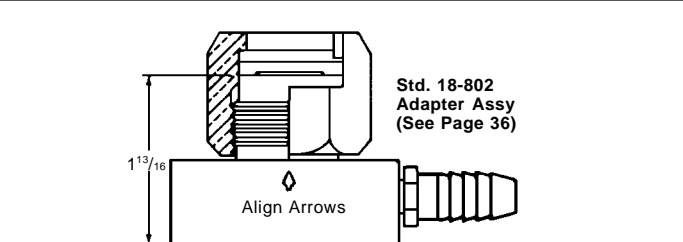
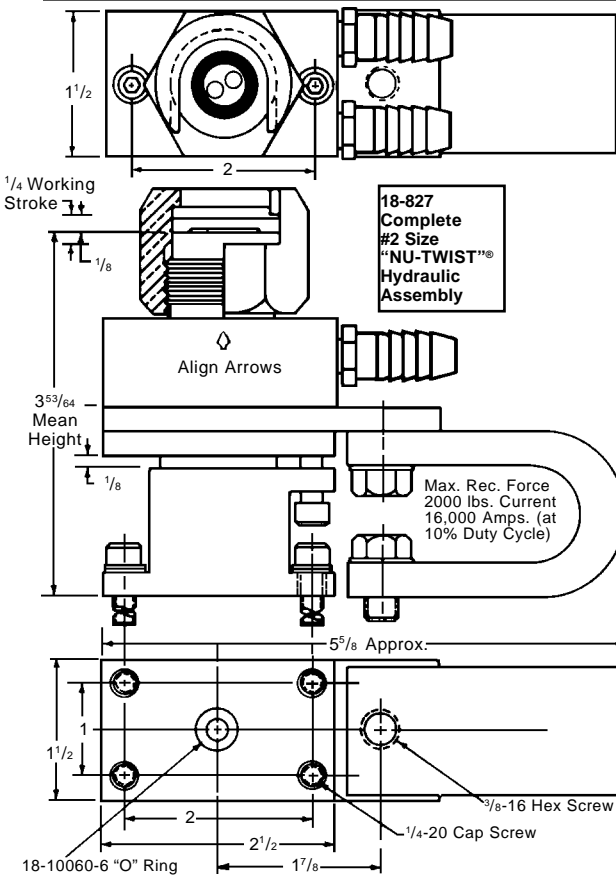

ASSEMBLIES OF HYDRAULIC "Nu-Twist"® NUMBERS 18-846, 18-847, AND 18-836

NSRW Co., Inc. (800) 933-6779, FAX: (205) 663-3221 Authorized Distributor CMW Inc.



CONTACT FACTORY
ALL ITEMS ON
THIS PAGE
PRICED and MADE
TO
SPECIAL ORDER

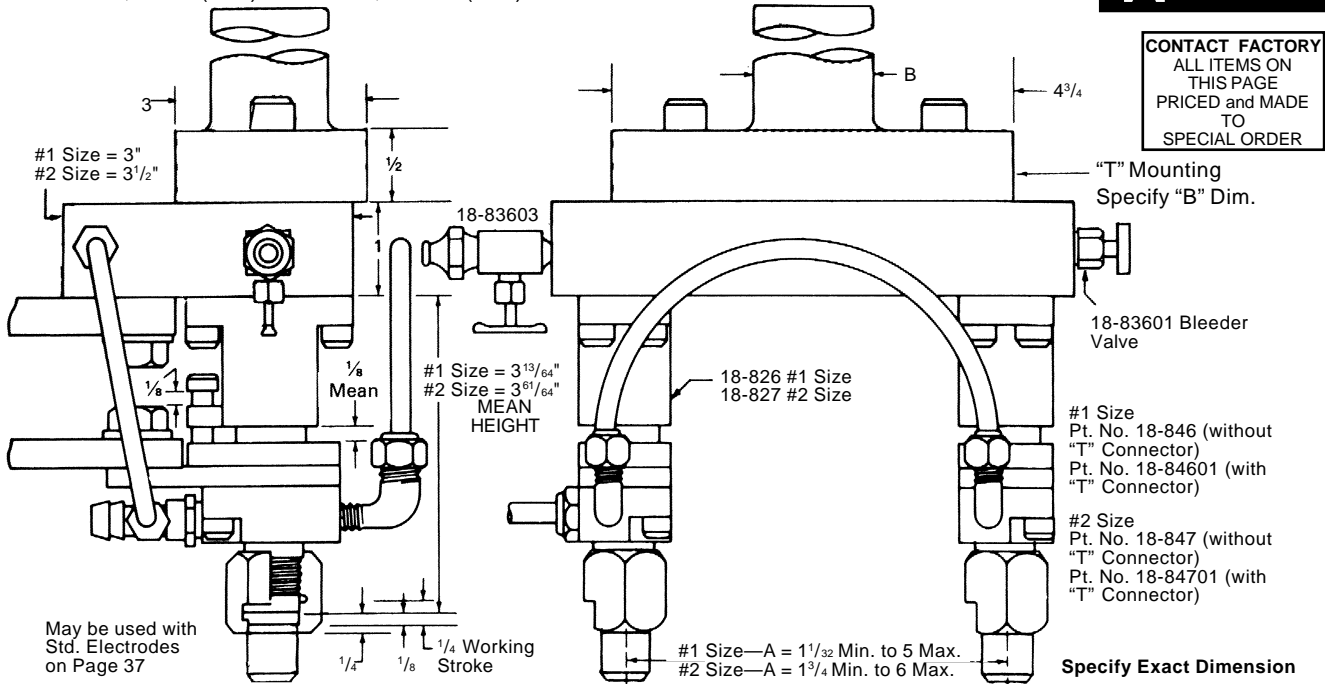

MAXIMUM RECOMMENDED WELD FORCE: #1 Size 1000# per 18-826 Unit 12,000 Amps. @ 10% Duty Cycle
#2 Size 2000# per 18-827 Unit 16,000 Amps. @ 10% Duty Cycle

Part No. 18-836 (shown below) is a typical assembly using two 18-826 assemblies set up as a complete self-contained unit for making two spot welds at one time. **This unit is so arranged as to allow the center distances to be readily adjusted from 1 1/32" centers to 2 1/4" centers or by rearrangement of the same parts centers may be adjusted from 2 1/4" to 3 1/2" centers.** This set up also include facilities for filling and bleeding the hydraulic units. "T" Mounting 18-83614 is available to order for Assembly 18-836.

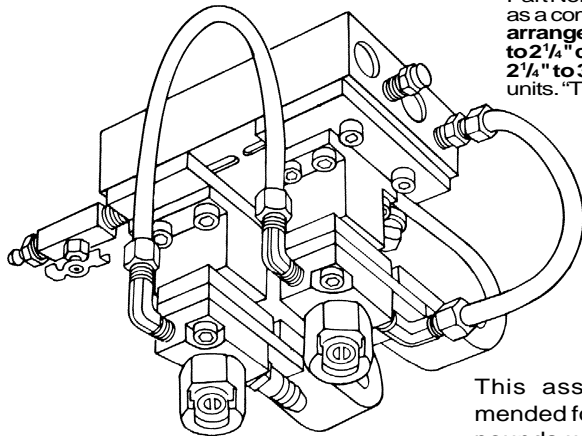

This assembly is recommended for use at up to 1000 pounds weld force per electrode and at up to 12,000 amperes secondary weld current at 10% duty cycle.

View of Base for 18-836 Shunt Side of Assembly

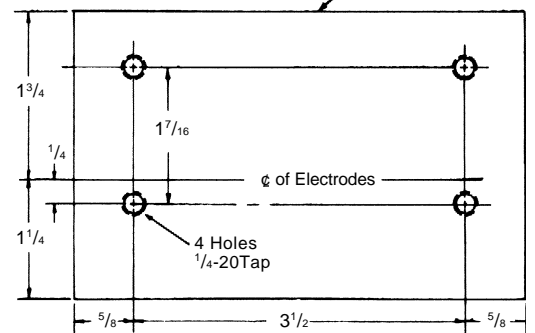

CMW "Nu-Twist"® ADAPTERS BUILDING BLOCKS FOR DIES AND BACKUPS

- Easy electrode changeover for minimum downtime
- Uniform height of electrode easily maintained for equal backup height
- Easily located for stepped or irregular shapes
- Provides low-cost standard building block for backup or die insert
- Permit building of lower-cost water-cooled die bases or backup dies
- Side removal requires minimum clearance for electrode replacement

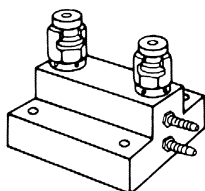

Near-flush mounting
water is brought through base

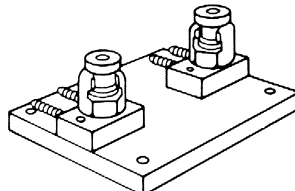

Permit use of
simple plate-type die base

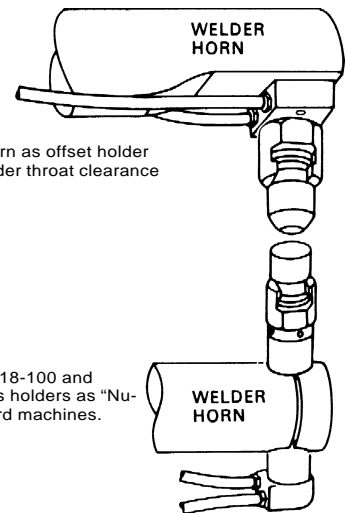

Use of welder horn as offset holder
for minimum welder throat clearance

Use with CMW standard 18-100 and 18-200 and 18-300 series holders as "Nu-Twist" holders on standard machines.

1100 SERIES ADJUST-A-PRESSURE WATER COOLED LOW INERTIA ELECTRODE HOLDERS

NSRW Co., Inc. (800) 933-6779, FAX: (205) 663-3221 Authorized Distributor CMW Inc.

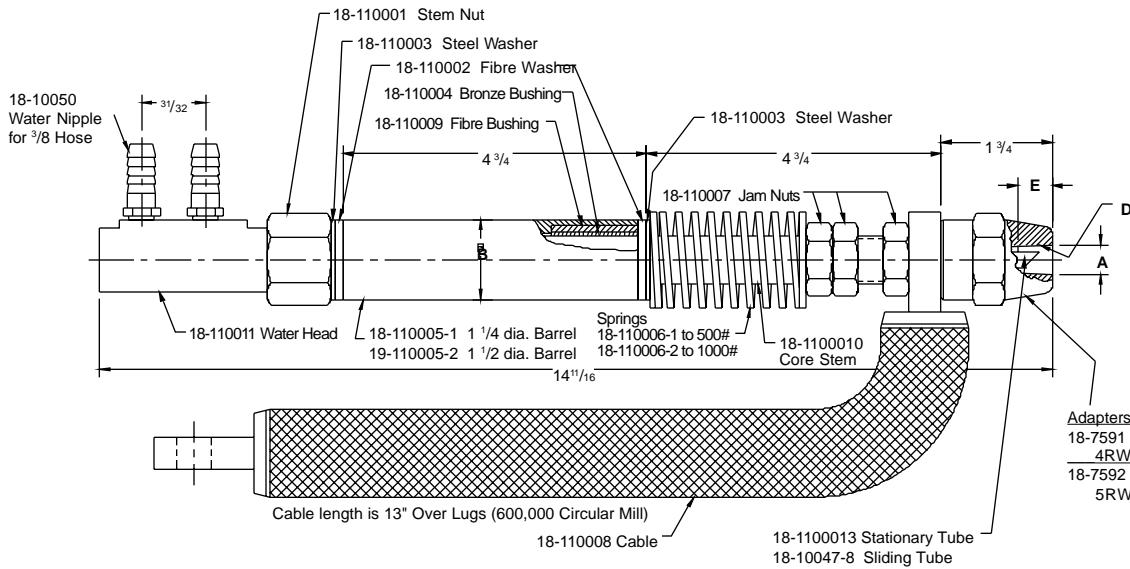

Like other low-inertia holders the heavy duty Adjust-A-Pressure Holders are used for multiple spot and projection welding, and are excellent for indirect welding when mounted in the Adjust-A-Angle Adapter.

Electrical current is conducted through heavy flexible cables and the holder is insulated to prevent any damaging effects to the spring mechanism. Light duty springs supplied to order.

HOLDER ASSEMBLY PART NUMBER	A Major Taper Dia.	B Barrel Dia.	D Taper	E Standard Electrode Taper Engagement	PRESSURE Range (Pounds)
18-1101	.463	1 1/4	4RW 1MT	1/2	TO
18-1102	.625	1 1/4	5RW 2MT	3/4	
18-1103	.463	1 1/2	4RW 1MT	1/2	500
18-1104	.625	1 1/2	5RW 2MT	3/4	

STANDARD ASSEMBLY USES
18-110006-1 SPRING

1150 SERIES ADJUST-A-ANGLE ADAPTERS

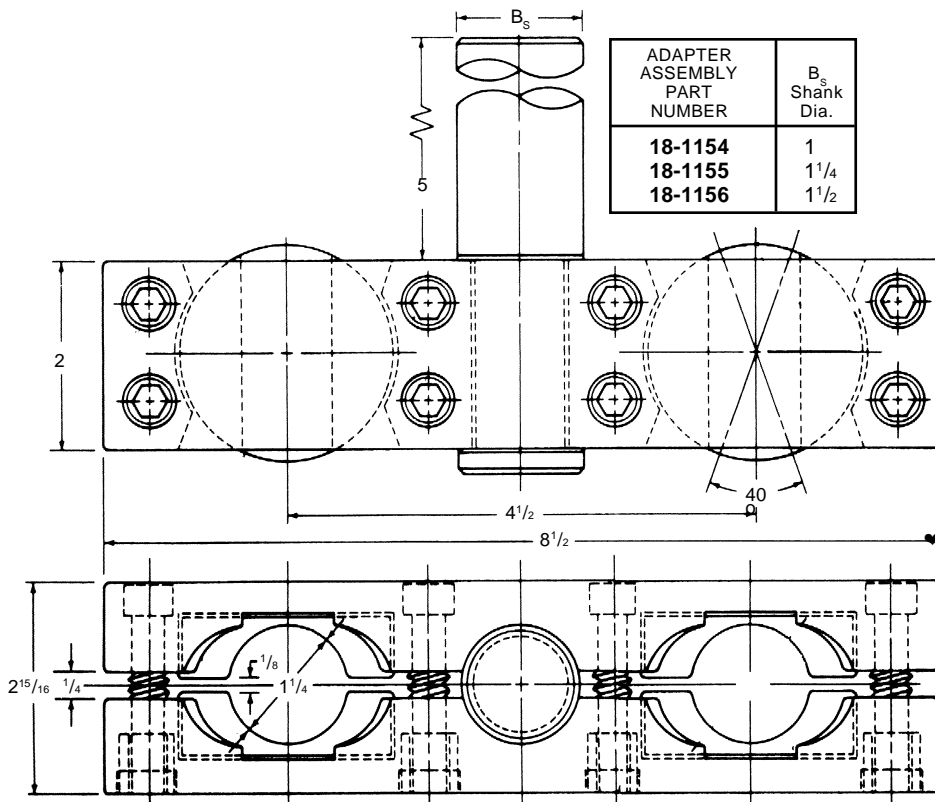

ADAPTER ASSEMBLY PART NUMBER	B _s Shank Dia.
18-1154	1
18-1155	1 1/4
18-1156	1 1/2

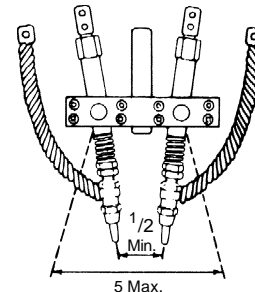

1100 SERIES HOLDERS ASSEMBLED IN 1150 SERIES ADAPTER

1150 series adjust-a-angle adapters are adaptable for use with spring type low inertia holders 1100 series as well as straight holders 100, 200, and 300 series.

ADAPTERS FOR BARREL SIZES OTHER THAN 1 1/4 DIA. MADE ONLY TO SPECIAL ORDER

APPLICATION SHEET FOR TYPICAL MULTIPLE SPOT WELDING SET UPS

NSRW Co., Inc. (800) 933-6779, FAX: (205) 663-3221 Authorized Distributor CMW Inc.



Typical Set Up For 3 Spots at a time in Parallel

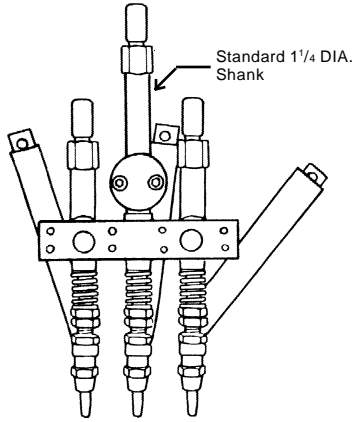

- 1 CMW Std. 1150 Series Adapter
- 2 CMW Std. 1100 Series Holders
- 1 CMW Special 1100 Series Holder

4RW-16-582011-01
5RW-16-582012-01

1/4" Dia. Shank Standard

Typical Set Up for 2 spots simultaneously in parallel

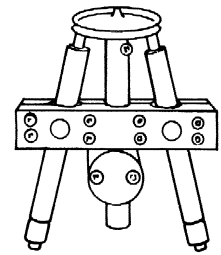
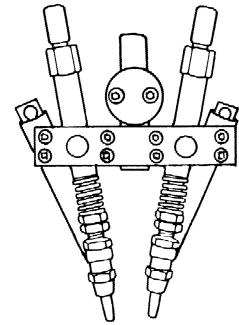

- Upper
2-1100 Series Holders
1-1150 Series Adapter

- Lower
2-100, 200 or 300 Series Holders
1-1150 Series Adapter with special center shank

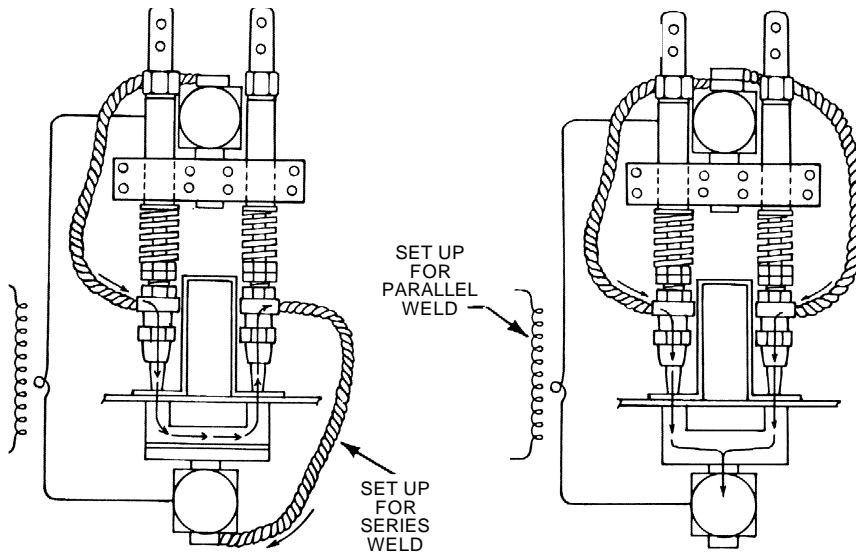

TYPICAL SET UP OF 800 SERIES "Nu-Twist"® UNITS

CONTACT FACTORY
ALL ABOVE ITEMS
PRICED and MADE
TO SPECIAL ORDER

ILLUSTRATIONS
ONLY

For dual spot welding using hydraulic "Nu-Twist"® pressure equalizing subassemblies and surface mounted adapters as basic building blocks

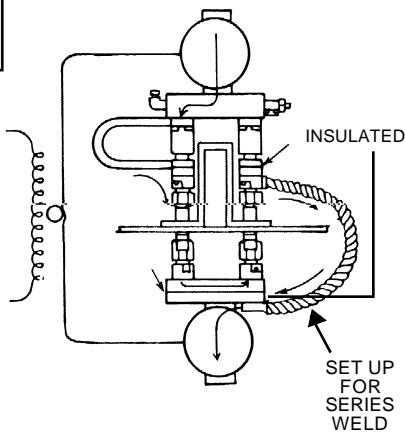

Upper
two
18-826
hydraulic
unit assemblies
mounted on
fixed
centers
(See Pages
38 and 39)

Lower
Two
18-801
surface
mounted
"Nu-Twist"®
Adapters
(See Page 36)

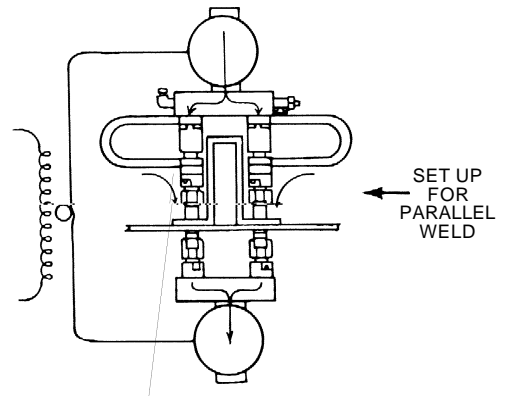

900 SERIES LIGHT DUTY WATER COOLED UNIVERSAL HOLDER

NSRW Co., Inc. (800) 933-6779, FAX: (205) 663-3221 Authorized Distributor CMW Inc.



**Note: Sold as a sub-assembly.
Water nipple—tube assembly
18-90041-1
Water nipple 18-10050
#10-32 cap screw 18-82167-2
90° 1/8 pipe ell 18-71150-1

May be purchased separately
18-71150-1
90° 1/8 Pipe Ell
18-10050 Water Nipple for 3/8 Hose
18-90041-1 Water Nipple Tube Assembly for 3/8 Hose

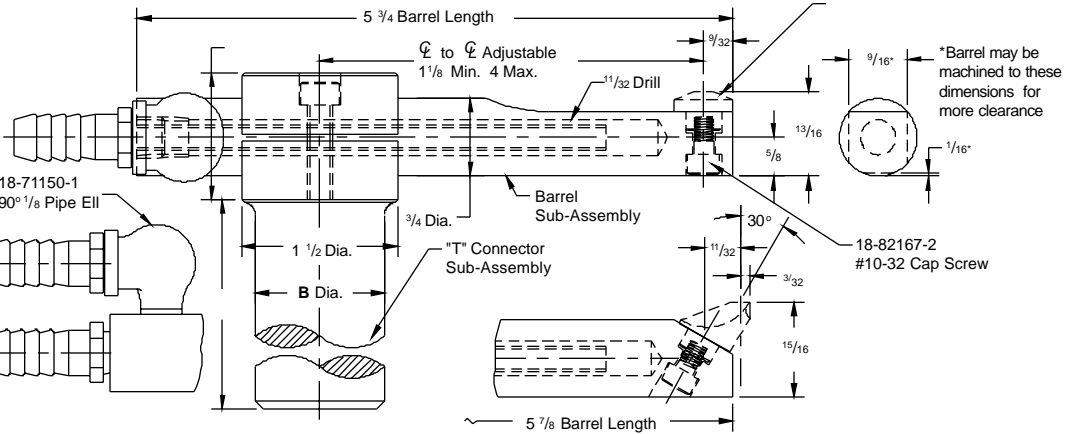

HOLDER ASSEMBLY PART NUMBER	Holder Angle	B Shank Dia.	Barrel Sub-Assembly**	"T" Connection*	Barrel*
18-901	90°		18-709		18-70910-1
18-902	30°	3/4	18-710	18-720	18-71010-1
18-903	90°		18-709		18-70910-1
18-904	30°	7/8	18-710	18-721	18-71010-1
18-905	90°		18-709		18-70910-1
18-906	30°	1	18-710	18-722	18-71010-1
18-907	90°		18-709		18-70910-1
18-908	30°	1 1/4	18-710	18-723	18-71010-1

Holders of Other Shank Diameters and Lengths or Design Modifications Are Available on Request as Specials.

950 SERIES WATER COOLED PADDLE HOLDER

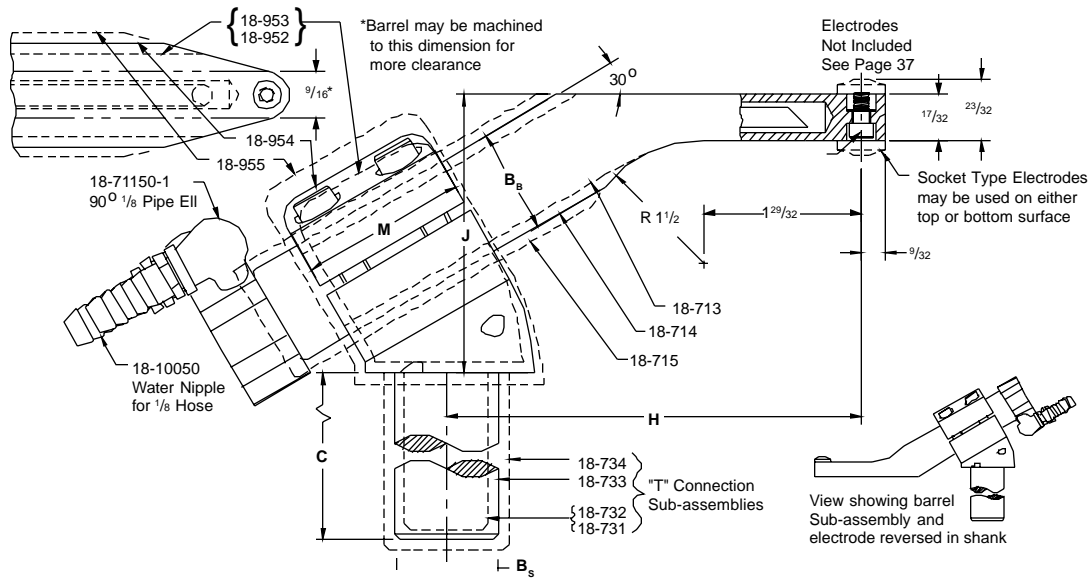

The Paddle Holder's heavy duty construction enables it to be used at high pressures in hard to reach spots. A minimum clearance is required. The barrel is adjustable in the "T" connection by both rotation and amount of offset.

HOLDER ASSEMBLY PART NUMBER	HOLDER SIZE						Barrel Sub-Assembly**	"T" Connector
	B Barrel Dia.	B _s Shank Dia.	C Shank Length	H Offset Range	J Height Range	M "T" Width		
18-952 18-953	1	7/8 1	3	3 ³ / ₈ to 5 ³ / ₃₂	2 ¹ / ₁₆ to 3 ¹ / ₁₆	1 1/2	18-713	18-731 18-732
18-954 18-955	1 1/4 1 1/2	1 1/4 1 1/2	3 1/2 4	4-5 ²³ / ₃₂ 4 ⁷ / ₃₂ -5 ¹⁵ / ₁₆	2 ³ / ₄ -3 ³ / ₄ 2 ⁷ / ₈ -3 ⁷ / ₈	1 3/4 2	18-714 18-715	18-733 18-734

Holders of other Shank Dia. and Lengths or Design Modifications are available on request as Specials.

**Note: Sold as a sub-assembly
Water nipples 18-10050
90° 1/8 pipe ells 18-71150-1
10-32 cap screw 18-82167-2
May be purchased separately.

These 30° "T" connector may be interchanged with the 90° Universal Type "T" Conn. page 35. See page 28 for suggested set ups.

PLATEN MOUNTED ELECTRODE HOLDERS

NSRW Co., Inc. (800) 933-6779, FAX: (205) 663-3221 Authorized Distributor CMW Inc.



CMW platen mounted electrode holders provide an economical means of mounting a wide range of electrodes in all the popular sizes to your press type welder platens. They are machined R.W.M.A. class 2 material to provide years of reliable service.

Part No. 18-0510-12

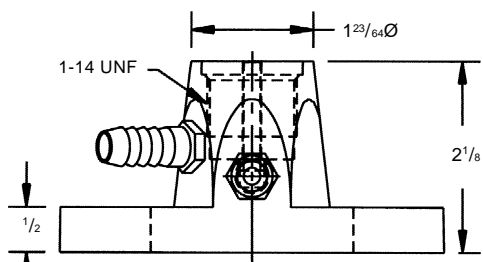
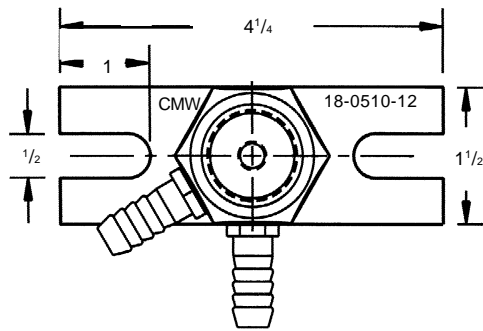

Silver Plated Mounting Surface for Maximum Conductivity

Part No. 18-0520-12

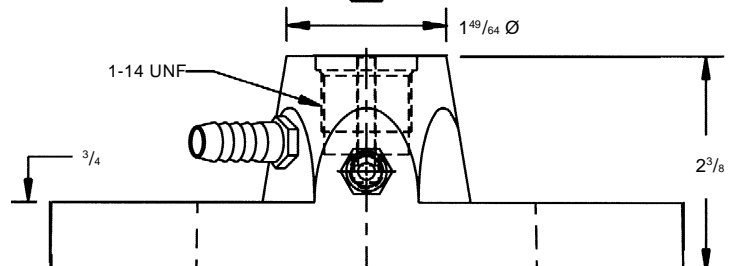
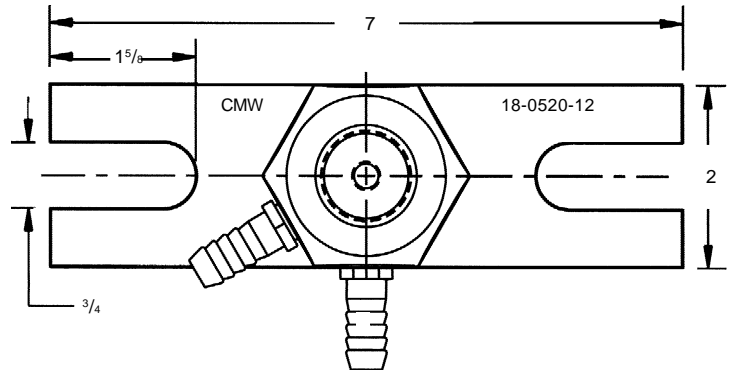

Silver Plated Mounting Surface for Maximum Conductivity

CMW platen mounted electrode holders are machined from CMW® 3 (RWMA class 2) chrome copper castings. They are designed to mount to press type welder platens from size #1 with the small holder to sizes #2 and #3 with the large holder. Both holders are provided with a 1-14 internal thread which will accept the standard male thread to female taper adapters, #4RW, #5RW, #6RW, and #7RW, as shown on page 27 of this catalog, and the #2 size "Nu-Twist"™ threaded adapter as shown on page 36 of this catalog. Both holders are provided with inlet and outlet water nipples for standard 3/8" water lines and a stationary water tube. Adapters and sliding water tubes must be ordered separately, by part number as required (see fig. #1).

The CMW platen mounted holder, as indicated in figure #2, has the inlet water nipple at position #1, and the outlet water nipple at position #2, any other combinations may be special ordered by changing the last two digits of the part number. The first of the last two digits indicates the location of the inlet nipple and the second digit indicates the location of the outlet nipple.

Example; part #18-0510-56 would place the inlet water nipple at position #5 and the outlet water nipple at position #6.

When ordering either CMW PM holder also specify the adapter(s) and sliding tube(s) required for your application.

1-14 male thd to female taper adpt. as shown on page 27 of this catalog.	ATTACHMENT	SLIDING TUBE	SLIDING TUBE O.A.L.
18-785	4RW	18-50041-3	1 3/8
18-786	5RW	18-40043-11	1 3/8
18-7863	6RW	18-40043-14	2 1/8
18-787	7RW	18-40043-15	2 3/8
18-812	#2 SIZE "Nu-Twist"™	NONE	-

STATIONARY WATER TUBE

18-40041-5

Additional Sliding Tubes Available	O.A.L.	FOR TAPER
18-50041-2	2 1/2	4RW
18-40043-5	2	5RW
18-40043-9	4	5RW,6RW,7RW

18-7743

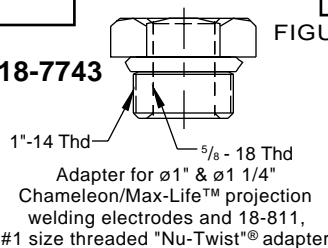
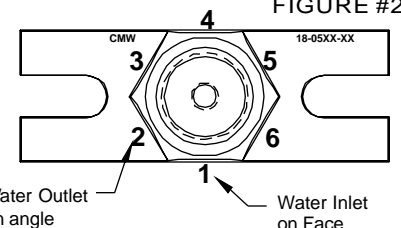

FIGURE #1

FIGURE #2



MULTI-SPOT WELDER ELECTRODE ADAPTERS



NSRW Co., Inc. (800) 933-6779, FAX: (205) 663-3221 Authorized Distributor CMW Inc.

CMW Electrode adapters for multispot air or hydraulic pistons are supplied with 3/4 diameter straight piston rod ends. These adapters are equipped with means for attaching the welding cable from the transformer and the water hoses to the inlet and outlet water connections.

These adapters are available in four basic assemblies as shown in the table.

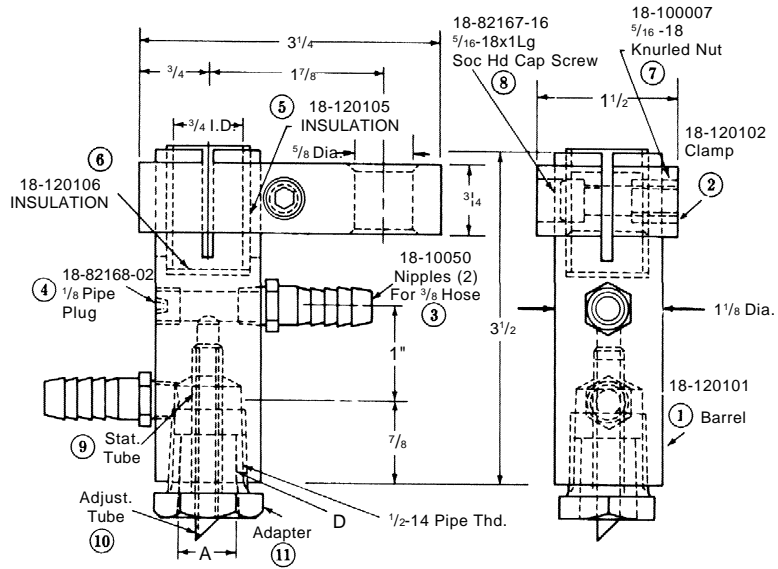

ASSEMBLY PART NO.	ⓓ Attachment Dia.	Ⓐ Major Taper Part No.	ⓑ Stat. Tube Part No.	Ⓒ Adj. Tube Part No.	Ⓙ Adapter Part No.*
18-1201	1/2-14 NPT	—	18-50046-1	18-10046-23	—
18-1202	5RW 2MT Male Cap	.4145	18-50046-1	—	18-7465-07
18-1203	4RW 1MT	.463	18-50046-1	18-10046-23	18-746-07
18-1204	5RW 2MT	.625	18-50046-1	18-10046-23	18-747-07

*See Page 27 for detail description. All assemblies include items 1, 2, 3, 4, 5, 6, 7, 8, and 9.

WELDING MACHINE CONTROL CONTACTORS

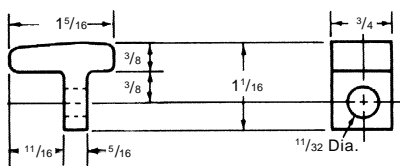

Part No. 16-1306

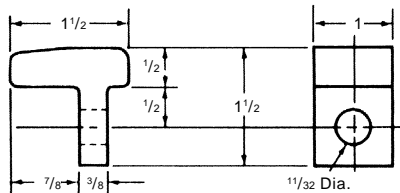

Part No. 16-1307

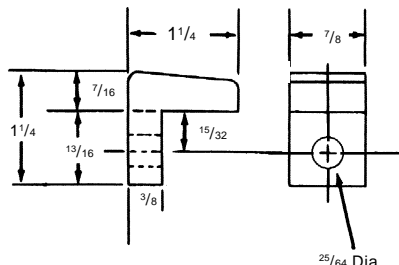

Part No. 16-1309

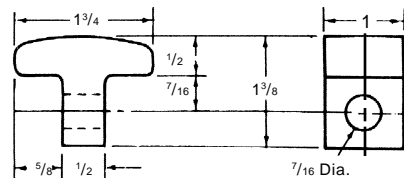

Part No. 16-1303

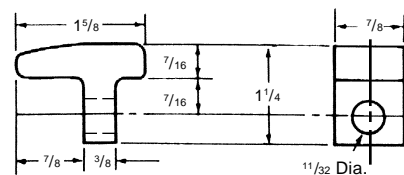

Part No. 16-1304

For use primarily in resistance welding controls. CMW maintains standard stocks of the five contacts listed. They consist of CMW® 353 material, a predominately copper alloy possessing arc resisting properties.

CMW® 353 Material has the ability to interrupt the current in a short time with minimum arc hang-

over. Because of the arc resistant characteristics of the metal, only the desired number of cycles of current are transmitted to the welding machine. Uniform welding quality is obtained because no additional current passes through the control, since CMW® 353 Material tends to prevent the arc from restriking.

ACCESSORIES

NSRW Co., Inc. (800) 933-6779, FAX: (205) 663-3221 Authorized Distributor CMW Inc.



REAMERS

High speed steel reamers to rework worn tapers in holders are available for standard 4RW 1MT, 5RW 2MT, 6RW and 7RW 3MT, and 4RW 1MT, 5RW 2MT, and 6RW Cap tapers. All reamers except for the 4RW 1MT are hollow, making it possible to recondition worn holder tapers without removing the water tubes.

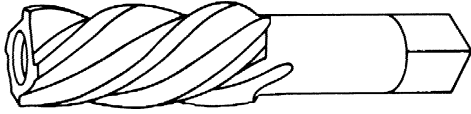

4RW 1MT	Part No. 18-1322
5RW 2MT	Part No. 18-1323
6RW	Part No. 18-1321
7RW 3MT	Part No. 18-1324
4RW 1MT cap taper	Part No. 18-1327
5RW 2MT cap taper	Part No. 18-1328
6RW cap taper	Part No. 18-1329

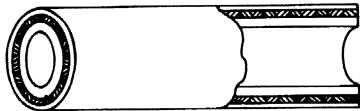

WATER COOLING HOSE — PART NO. 18-1350

CMW water-cooling hose is the finest available. Made by a prominent hose manufacturer. This hose is $\frac{3}{8}$ " diameter which properly fits the water nipples on CMW holders. It is available in 50-foot coils or can be cut to length.

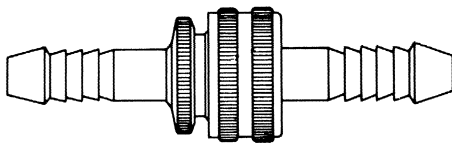

HOSE CONNECTOR FOR $\frac{3}{8}$ " HOSE—PART NO. 18-1351

This hose connector, placed in the water-cooling hose line, facilitates quick change of holders or dies. The male and female ends of these connectors should be reversed in the inlet and outlet lines to eliminate confusion in changing set-ups.

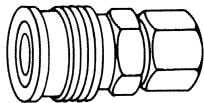

SOCKET
($\frac{1}{8}$ " Female Pipe Thd.)
18-135200-1



PLUG
($\frac{1}{8}$ " Male Pipe Thd.)
18-135200-2

QUICK CONNECTIVE COUPLING ASSEMBLY PART NO. 18-1352

The plug of this coupling can be mounted on CMW holders converting them for quick hose changes. An automatic water shut-off valve is built into the coupling.

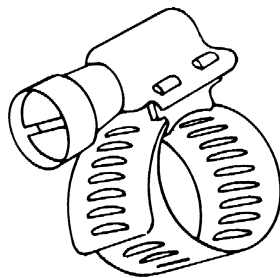

HOSE CLAMP — PART NO. 18-1353

This aircraft type hose clamp gives positive tightening action which eliminates water leakage. It is easy to install and remove from Standard $\frac{3}{8}$ " Water Hose.

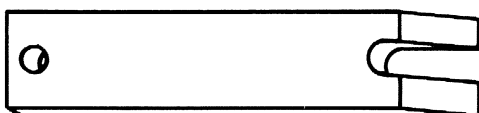

CAP ELECTRODE EXTRACTOR FORK

18-1381-1 FOR 5RW CAPS
18-1381-2 FOR 4RW CAPS

These hardened steel wedge type forks will make the removal of electrode caps quick and easy. They can be used on both female and male caps.

ELECTRODE DRESSING CUTTERS AND ACCESSORIES

NSRW Co., Inc. (800) 933-6779, FAX: (205) 663-3221 Authorized Distributor CMW Inc.



ELECTRODE DRESSING ACCESSORIES

TO DRESS Standard RWMA 4 (#1 MT)								
	NOSE STYLE (CMW ELECTRODE NO.)	DOME x11x...	POINTED x21x...	FLAT x31x...	2" RADIUS x51x...	3" RADIUS x81x...	4" RADIUS x91x...	10" RADIUS x61x...
KIT** TO ORDER	18-1390411	18-1390420	18-1390410	18-1390413	18-1390414	18-1390415	18-1390416	18-1390412
Replacement Blade (for above kit)	18-139411	18-139420	18-139410	18-139413	18-139414	18-139415	18-139416	18-139412
Replacement Guide Ring (for above kit)	18-139401	18-139402	18-139401	18-139401	18-139401	18-139401	18-139401	18-139401

****Note:** Each Kit includes Stud (for 3/8" keyed chuck), Chuck, 1 Guide Ring, 1 appropriate Blade, and Retaining Nut.

This kit is appropriate for use with either Pneumatic Power Tool (18-1310) or any rotary device with 3/8" keyed chuck. The Pneumatic Power Tool is recommended for dressing while installed in the welder.

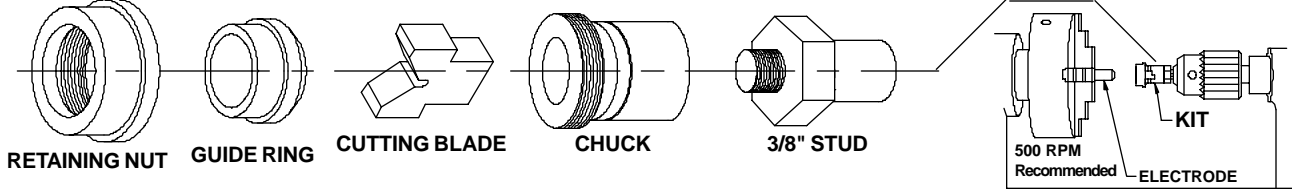

TO DRESS Standard RWMA 5 (#2 MT)								
	NOSE STYLE (CMW ELECTRODE NO.)	DOME x12x...	POINTED x22x...	FLAT x32x...	2" RADIUS x52x...	3" RADIUS x82x...	4" RADIUS x92x...	10" RADIUS x62x...
KIT** TO ORDER	18-1390511	18-1390520	18-1390510	18-1390513	18-1390514	18-1390515	18-1390516	18-1390512
Replacement Blade (for above kit)	18-139511	18-139520	18-139510	18-139513	18-139514	18-139515	18-139516	18-139512
Replacement Guide Ring (for above kit)	18-139501	18-139502	18-139501	18-139501	18-139501	18-139501	18-139501	18-139501

Note: Cutters are not designed to conform to "Electrode Cap" geometries. Caps are intended for metal value salvage when expended.

ELECTRODE DRESSERS



NSRW Co., Inc. (800) 933-6779, FAX: (205) 663-3221 Authorized Distributor CMW Inc.

PNEUMATIC POWER HANDLE FOR ELECTRODE DRESSING PART NO. 18-1310

Light weight and rugged construction, this CMW Pneumatic Power Handle requires a clearance of only 1 1/2" with a standard ring and 2" with an extended ring. In most situations this allows dressing of electrodes without removal from the welder. Operating at a cutting speed of 1200 RPM, it enables the operator to dress electrodes quickly and accurately. Cutters and guide rings are easily replaced. These must be matched to the electrode nose and are selected from the chart on page 46.

CMW Electrode Dresser 18-1310 is supplied without blade holder, ring and cutter blade. When ordering, specify the "Kit" appropriate for your dressing needs as selected from the table on page 46.

(The "stud" furnished with the "Kit" is not required when using the Pneumatic Power Handle. It may optionally be used, but will increase the clearance required on the welder for dressing).

Additional special cutters can be furnished upon request.

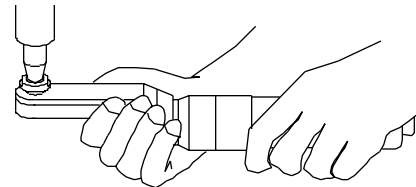
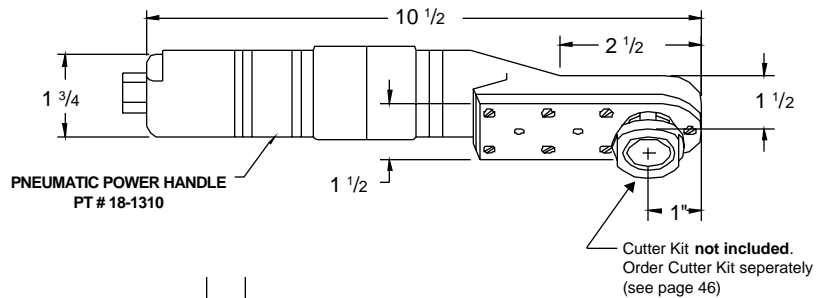

Electrode Dresser — Part No. 18-1307

The Electrode Dresser quickly removes the "mushroomed" portions of spot welding electrodes and renews 4RW or 5RW Taper, dome or pointed electrodes with the proper operating contour. The Electrode Dresser re-machines *both* upper and lower electrodes to the correct profile "on the job"—provided both electrodes are identical—without removal of the electrodes from their holders. Dresser is 10" long, with a replaceable cutter of hardened tool steel.



Order replaceable cutters by—18-130701
Order replaceable handle by—18-130702

ELECTRODE DRESSER PART NO. 18-1370

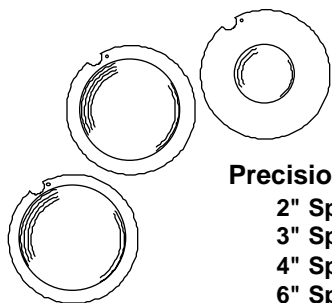

Precision Ground Contour Plates

- 2" Sphr. Rad. - 18-137001
- 3" Sphr. Rad. - 18-137002
- 4" Sphr. Rad. - 18-137003
- 6" Sphr. Rad. - 18-137004
- 8" Sphr. Rad. - 18-137005
- 10" Sphr. Rad. - 18-137006

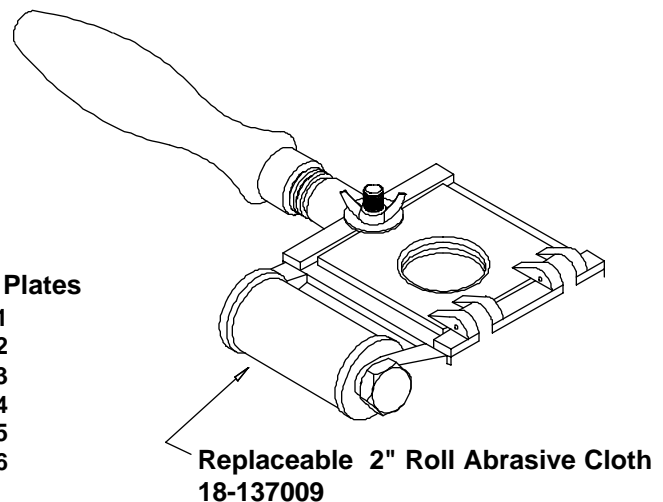

Electrodes Dressed to Any Radius Without Removal from Welder

In certified resistance welding and where clean, strong welds are necessary on a production basis the Maintain-A-Contour Dresser pays big dividends. Its use not only assures consistent quality welds in aircraft metals, but saves valuable production time in all dressing operations.

The Maintain-A-Contour Dresser is supplied with a spool of 240 grit cloth, and one set of (2 per set) precision ground contour plates. Specify the size radius (2"—3"—4"—6"—8"—10") plates required.

Plates with special radii are available on special request. The abrasive cloth is standard 2" width.

WELDING BAR AND ROD STOCK

NSRW Co., Inc. (800) 933-6779, FAX: (205) 663-3221 Authorized Distributor CMW Inc.



DIAMETER THK. WTH. (INCHES)	RWMA ALLOY CLASS NO.	CMW® ALLOY NO.	CMW PART NUMBER	WEIGHT/LBS.	
				INCH	FOOT
Rounds					
1/8	2	CMW®3	58704	.012	.147
1/4	2	CMW®3	58707	.016	.192
3/8	2	CMW®3	58712	.035	.420
7/16	2	CMW®3	58713	.048	.576
.482	2	CMW®3	50333	.058	.696
.482	1	CMW®28	65256	.058	.696
1/2	2	CMW®3	58715	.063	.756
.500	2	CMW®3	58715	.063	.756
.500	1	CMW®28	64124	.063	.756
.625	1	CMW®28	64126	.099	1.188
1/2	3	CMW®100	75836	.063	.756
5/8	2	CMW®3	58716	.099	1.188
5/8	3	CMW®100	75835	.099	1.188
3/4	2	CMW®3	58708	.142	1.704
3/4	1	CMW®28	66526	.142	1.704
7/8	2	CMW®3	58719	.193	2.316
7/8	3	CMW®100	75736	.193	2.316
1.0	2	CMW®3	58710	.251	3.012
1-1/4	2	CMW®3	58720	.395	4.740
1-1/4	3	CMW®100	59035	.395	4.740
1.260	2	CMW®3	59840	.396	4.752
1-1/2	2	CMW®3	58724	.568	6.816
1.510	2	CMW®3	52217	.570	6.840
2.0	2	CMW®3	58731	1.010	12.120
2.0	3	CMW®100	75838	1.010	12.120
2-1/2	2	CMW®3	58767	1.580	18.960
3-1/8	2	CMW®3	51235	2.470	29.640
Hex					
.250 Hex	2	CMW®3	79072	.013	.156
.375 Hex	3	CMW®100	79993	.029	.348
.438 Hex	2	CMW®3	79556	.040	.480
.438 Hex	3	CMW®100	79544	.040	.480
.500 Hex	2	CMW®3	76569	.052	.624
.500 Hex	3	CMW®100	75450	.052	.624
.625 Hex	2	CMW®3	68487	.081	.972
.750 Hex	2	CMW®3	58755	.117	1.404
.750 Hex	3	CMW®100	78781	.117	1.404
.875 Hex	2	CMW®3	58756	.160	1.920
1.000 Hex	2	CMW®3	58655	.208	2.496
1.000 Hex	3	CMW®100	55848	.208	2.496
1.125 Hex	2	CMW®3	52956	.264	3.168
1.125 Hex	3	CMW®100	79933	.264	3.168
1.250 Hex	2	CMW®3	73784	.326	3.912
1.250 Hex	3	CMW®100	67490	.326	3.912
1.500 Hex	3	CMW®100	50561	.469	5.628
Squares and Rectangles					
1/4 x 1-1/2	2	CMW®3	58881	.120	1.440
1/2 x 1/2	2	CMW®3	58766	.080	.960
5/8 x 5/8	2	CMW®3	58677	.125	1.500
1 x 1	2	CMW®3	58690	.320	3.840
1 x 1-1/2	2	CMW®3	50322	.480	5.760
1 x 2	2	CMW®3	58759	.640	7.680
1 x 3	2	CMW®3	50324	.960	11.520
1-1/2 x 3	2	CMW®3	74630	1.440	17.280
	3	CMW®353	VARIOUS SHAPES AND SIZES AVAILABLE IN THESE MATERIALS. CONSULT CMW INC. CUSTOMER SERVICE FOR PRICE AND DELIVERY INFORMATION.		
	4	CMW®73			
	5	ELKALOY®D			
	10	ELKONITE®1W3			
	11	ELKONITE®10W3			
	12	ELKONITE®30W3			
	13	ELKON®100W			
	14	ELKON®100M			

ELKONITE® BAR STOCK

NSRW Co., Inc. (800) 933-6779, FAX: (205) 663-3221 Authorized Distributor CMW Inc.



TYPICAL PROPERTIES OF ELKONITE® MATERIALS (See CMW Inc. Catalog Series 200)

Elkonite® Material	Composition % by Weight	Density		Electrical		Theoretical		Hardness (Rockwell)	Modulus of Rupture In Bending		ASTM Specification
		g/cm or (Mg/m³)	lb/In³	Conductivity %IACS	Resistivity (n-ohm-m)	Thermal Btu-h⁻¹-ft¹-F¹	Conductivity (W-m⁻¹-K¹)		pal	(MPa)	
1W3	55W:45Cu	12.50	.452	53	(32.5)	180	(310)	77HRB	110.000	(758)	B702
3W3	68W:32Cu	13.93	.503	50	(34.5)	160	(280)	90HRB	130.000	(896)	B702
5W3	70W:30Cu	14.18	.512	48	(35.9)	160	(280)	95 HRB	140.000	(965)	B702
10W3	75W:25Cu	14.84	.536	45	(38.3)	150	(260)	98 HRB	150.000	(1030)	B702
10W53	75W:25Cu*	14.79	.534	28	(61.6)	85	(150)	109 HRB	200.000	(1380)	B702
30W3	80W:20Cu	15.56	.562	41	(42.1)	145	(250)	103 HRB	170.000	(1170)	B702
TC5	50WC:50Cu	11.26	.408	45	(38.3)	170	(290)	94 HRB	160.000	(1100)	-
TC10	56WC:44Cu	11.64	.421	42	(41.0)	160	(280)	100 HRB	180.000	(1240)	-
TC20	70WC:30Cu	12.65	.457	30	(57.5)	140	(240)	37 HRC	200.000	(1380)	-

*Cu Alloy 10W53 FULLY HEAT TREATED

ELKONITE® 10W3 ROUND BARS-8 INCH LENGTH

FINISHED DIAMETER	PART NUMBER	FINISHED DIAMETER	PART NUMBER
1/8	15-140200-64	3/4	15-141200-64
3/16	15-140300-64	7/8	15-141400-64
1/4	15-140400-64	1	15-141600-64
5/16	15-140500-64	1-1/8	15-141800-64
3/8	15-140600-64	1-1/4	15-142000-64
7/16	15-140700-64	1-3/8	15-142200-64
1/2	15-140800-64	1-1/2	15-142400-64
9/16	15-140900-64	1-3/4	15-142800-64
5/8	15-141000-64	2	15-143200-64

ELKONITE® 10W3 RECTANGULAR BARS-8 INCH LENGTH

SIZE-INCHES			SIZE-INCHES			SIZE-INCHES			
THICK	WIDTH	PART NUMBER	THICK	WIDTH	PART NUMBER	THICK	WIDTH	PART NUMBER	
1/8	1/8	15-140202-64	5/16	5/16	15-140505-64	1/2	1-1/2	15-142408-64	
	1/4	15-140402-64		3/8	15-140605-64		2	15-143208-64	
	5/16	15-140502-64		1/2	15-140805-64		4	15-146408-64	
	3/8	15-140602-64		5/8	15-141005-64	5/8	5/8	15-141010-64	
	1/2	15-140802-64		3/4	15-141205-64		3/4	15-141210-64	
	5/8	15-141002-64		1	15-141605-64		1	15-141610-64	
	3/4	15-141202-64		1-1/4	15-142005-64		1-1/4	15-142010-64	
	1	15-141602-64		1-1/2	15-142405-64		1-1/2	15-142410-64	
	1-1/4	15-142002-64		2	15-143205-64		2	15-143210-64	
	1-1/2	15-142402-64		4	15-146405-64	4	15-146410-64		
	2	15-143202-64		3/8	3/8	15-140606-64	3/4	3/4	15-141212-64
	4	15-146402-64			1/2	15-140806-64		1	15-141612-64
1/4	3/4	15-141203-64	5/8		15-141006-64	1-1/4		15-142012-64	
		1/4	15-140404-64		3/4	15-141206-64		1-1/2	15-142412-64
		5/16	15-140504-64		7/8	15-141406-64	2	15-143212-64	
		3/8	15-140604-64		1	15-141606-64	4	15-146412-64	
		1/2	15-140804-64	1-1/4	15-142006-64	1	1	15-141616-64	
		5/8	15-141004-64	1-1/2	15-142406-64		1-1/4	15-142016-64	
		3/4	15-141204-64	2	15-143206-64		1-1/2	15-142416-64	
		1	15-141604-64	4	15-146406-64		2	15-143216-64	
		1-1/4	15-142004-64	1/2	1/2		15-140808-64	4	15-146416-64
		1-1/2	15-142404-64		5/8		15-141008-64	1-1/4	15-142020-64
		2	15-143204-64		3/4	15-141208-64	1-1/2	15-142420-64	
		4	15-146404-64		1	15-141608-64	1-1/4	15-142420-64	
		1-1/4	15-142008-64						
					2	2	15-143232-64		

*Contact Factory For Additional Sizes

ORDER BY CMW PART NUMBER ONLY

FORCE GAUGES



NSRW Co., Inc. (800) 933-6779, FAX: (205) 663-3221 Authorized Distributor CMW Inc.

The examples listed below are stock items. If you would like us to build a force gauge to fit your needs, please refer to the table for available options. CMW also offers a digital force sensor. Please call for quotation.

STOCK FORCE GAUGES

Standard Part Number LC2564-73

2 1/2" sensor, 5.0" grip, 2,000 lbs. of force, 3/4" poly locator

Deluxe Part Number LC2164-7393

2 1/2" sensor, 5.0" grip, 2,000 lbs. of force, 15° flexible swivel connection, 3/4" poly locator, insulated back pad

AVAILABLE ON REQUEST

Digital Part Number LC8568-73

3 1/2" sensor, 5.0" grip, 5,000 lbs. of force, 3/4" poly locator

REPAIR AND REPLACEMENT PARTS

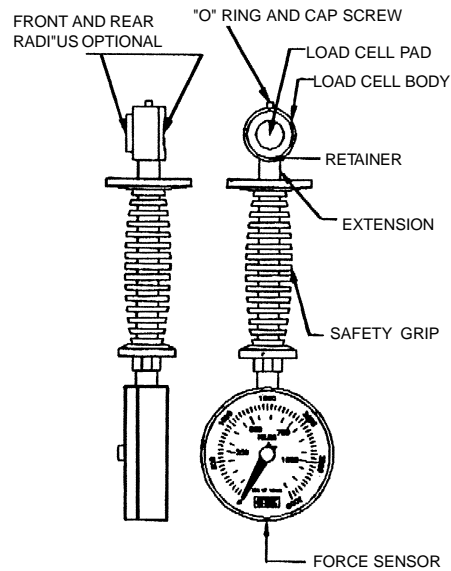

FORCE GAUGE OPTIONS

SENSOR	CONNECTOR	FORCE RANGE	PAD	REAR PAD
2.5" w/o pointer	15° flex swivel 11.0" OAL*	300	Flat Poly	Flat
2.5" w/pointer†*	90° flex swivel 15.0" OAL	600	Flat SS	
4.0" w/o pointer	180° flex swivel 19.0" OAL	1,000	3/4" Locator Poly †*	3/4" poly*
4.0" w/pointer		2,000†*	3/4" Locator SS	
4.5" process	Standard 5.0" grip	3,000	5.0" Radius Poly	5.0" Radius Poly
4.5" w/pointer	6.0" OAL w/o grip	5,000 ¹	5.0" Radius SS	
	Under 7.0" OAL	10,000 ²	Thin (low profile)	
Digital	Swivel only	¹ Must add SS live pad	Thin Poly	
		² SS live pad and flat rear pad	Thin SS	

† = Standard * = Deluxe

APPROXIMATE PRESSURE EXERTED BY AIR CYLINDER SIZE

DIAMETER	=	CYLINDER AREA SQ. INCHES	x	WELDER GAUGE PRESSURE	=	ELECTRODE FORCE PRESSURE
4"	=	12.5	x		=	
5"	=	19.5	x		=	
6"	=	28.0	x		=	
8"	=	50.0	x		=	

GCAP® WELD AND STEPPER SCHEDULE

NSRW Co., Inc. (800) 933-6779, FAX: (205) 663-3221 Authorized Distributor CMW Inc.



GCAP® ELECTRODE WELD SCHEDULE FOR GALVANIZED STEEL

Metal Thickness	.020	.030	.035	.040	.050	.060	.078	.093	.125
G-CAP	244	254	254	254	255	255	266	266	266
Pressure	300	400	500	650	750	800	1000	1200	1400
Squeeze cycle	25	25	25	25	30	30	30	35	35
Up-Slope cycle					4	4	4	4	5
Upslope Kiloamps					2.0 to S.C.*	2.0 to S.C.*	2.0 to S.C.*	2.0 to S.C.*	2.0 to S.C.*
Weld cycle	6	8	9	10	7	8	10	12	10
Kiloamps	8.5	9.0	9.5	10.0	10.5	11.0	11.5	12.5	13.5
Cool cycle					1	1	1	1	1
Weld cycle					7	8	10	12	10
Kiloamps					10.5	11.0	11.5	12.5	13.5
Cool cycle									1
Weld cycle									10
Kiloamps									13.5
Hold cycle	3	4	4	5	5	10	10	15	20

* S.C. – Starting Weld Current

GCAP® LINEAR STEPPER

Total Weld Count	500	1,000	3,000	5,000	7,500	10,000	12,000
Total Amps Boost	600	1000	3000	5000	6800	8400	9200
Amps Boost Per Weld	1.20	.88				.60	

The above schedules and stepper is only meant to be a guide and will require adjustments to fit the application.

APPLICATION DATA SHEET

NSRW Co., Inc. (800) 933-6779, FAX: (205) 663-3221 Authorized Distributor CMW Inc.



SPOT WELDING DATA

OPTIMUM CONDITIONS

SCHEDULES FOR SPOT WELDING LOW CARBON STEEL—SAE 1010

Thickness of Thinnest Outside Piece (Inches)	Electrode Diameters and Shape*			Recommended Minimum Standard Electrode Size	Weld Force (Lbs.)	Weld Time (Cycles) (60 Cycles per Sec.)	Hold Time (Cycles) (Min.)	Welding Current (Amps.) (Approx.)	Weld Shear Strength (For Steels Having Ultimate Tensile Strength of 90,000 psi and below) Minimum Strength (Lbs/Weld)	Diameter of Fused Zone (Approx.) Dw (Inches)	Minimum Weld Spacing S (Inches)	Minimum Contacting Overlap L (Inches)
	Flat Face		Radius Face									
	Maximum d (Inches)	Min. D (Inches)	Radius R (Inches)									
0.010	0.125	1/2	2	4RW 1MT	160	4	5	4,000	130	0.113	1/4	3/8
0.021	0.187	1/2	2	4RW 1MT	244	6	8	6,500	300	0.139	3/8	7/16
0.031	0.187	1/2	2	4RW 1MT	326	8	10	8,000	530	0.161	1/2	7/16
0.040	0.250	5/8	3	5RW 2MT	412	10	12	8,800	812	0.181	3/4	1/2
0.050	0.250	5/8	3	5RW 2MT	554	14	16	9,600	1,195	0.210	7/8	9/16
0.062	0.250	5/8	3	5RW 2MT	670	18	20	10,600	1,717	0.231	1	5/8
0.078	0.312	5/8	3	5RW 2MT	903	25	30	11,800	2,365	0.268	1 1/8	1 1/16
0.094	0.312	5/8	4	7RW 3MT	1,160	34	35	13,000	3,054	0.304	1 1/4	3/4
0.109	0.375	7/8	4	7RW 3MT	1,440	45	40	14,200	3,672	0.338	1 5/16	13/16
0.125	0.375	7/8	4	7RW 3MT	1,760	60	45	15,600	4,300	0.375	1 1/2	7/8
0.156	0.500	7/8	6	Male or Female Threaded	2,500	93	50	18,000	6,500	0.446	1 3/4	1
0.187	0.625	1	6	Male or Female Threaded	3,340	130	55	20,500	9,000	0.516	2	1 1/2
0.250	0.750	1 1/4	6	Male or Female Threaded	5,560	230	60	26,000	18,000	0.660	4	1 1/2

PERMISSIBLE SCHEDULE VARIATIONS FOR SPOT WELDING LOW CARBON STEEL

Low Carbon Steel Spot Welding Data Chart—Single Impulse Welding

DATA COMMON TO ALL CLASSES OF SPOT WELDS			WELDING SET-UP FOR BEST QUALITY—CLASS A WELDS					WELDING SET-UP FOR MEDIUM QUALITY—CLASS B WELDS					WELDING SET-UP FOR GOOD QUALITY—CLASS C WELDS						
Thickness of Each of the Two Work Pieces (Inches)	Electrode Diam. & Shape		Min. Weld Spacing (Note 4) (Inches)	Min. Contacting Overlap (Note 6) (Inches)	Weld Time (Note 7) (Cycles)	Electrode Force (Pounds)	Welding Current (Amps.)	Diam. of Fused Zone (Inches)	Average Tensile Shear Strength ±14% (Pounds)	Weld Time (Note 7) (Cycles)	Electrode Force (Pounds)	Welding Current (Amps.)	Diam. of Fused Zone (Inches)	Average Tensile Shear Strength ±17% (Pounds)	Weld Time (Note 7) (Cycles)	Electrode Force (Pounds)	Welding Current (Amps.)	Diam. of Fused Zone (Inches)	Average Tensile Shear Strength ±20% (Pounds)
	Min. D (Inches)	Max. d (Inches)																	
.010	1/2	1/8	1/4	3/8	4	200	4000	.13	235	5	130	3700	.12	200	15	65	3000	.11	160
.021	1/2	3/16	3/8	7/16	6	300	6100	.17	530	10	200	5100	.16	460	22	100	3800	.14	390
.031	1/2	3/16	1/2	7/16	8	400	8000	.21	980	15	275	6300	.20	850	29	135	4700	.18	790
.040	5/8	1/4	3/4	1/2	10	500	9200	.23	1305	21	360	7500	.22	1230	38	180	5600	.21	1180
.050	5/8	1/4	7/8	9/16	12	650	10300	.25	1820	24	410	8000	.23	1700	42	205	6100	.22	1600
.062	5/8	1/4	1	5/8	14	800	11600	.27	2350	29	500	9000	.26	2150	48	250	6800	.25	2050
.078	5/8	5/16	1 1/8	11/16	21	1100	13300	.31	3225	36	650	10400	.30	3025	58	325	7900	.28	2900
.094	5/8	5/16	1 1/4	3/4	25	1300	14700	.34	4100	44	790	11400	.33	3900	66	390	8800	.31	3750
.109	7/8	3/8	1 5/16	13/16	29	1600	16100	.37	5300	50	960	12200	.36	5050	72	480	9500	.35	4850
.125	7/8	3/8	1 1/2	7/8	30	1800	17500	.40	6900	60	1140	12900	.39	6500	78	570	10000	.37	6150

NOTES:

- Low Carbon Steel as hot rolled, pickled, and slightly oiled with an ultimate strength of 42,000 to 45,000 PSI Similar to SAE 1005—SAE 1010.
- Electrode Material is CMW® 3.
- Surface of steel is lightly oiled but free from grease, scale or dirt.
- Minimum weld spacing is that distance for which no increase in welding current is necessary to compensate for the shunted current effect in adjacent welds.
- Radius Face electrodes may be used:

0.010 to 0.031 — 2" Radius
 0.031 to 0.078 — 3" Radius
 0.078 to 0.125 — 4" Radius



6. Weld time is indicated in cycles of 60 cycle frequency.

7. Tensile shear strength values are based on

recommended test sample sizes:

Direction of Force Length	Thickness	Width
	.000" to .029"	5/8" 3"
	.030" to .058"	1" 4"
	.059" to .115"	1 1/2" 5"
	.116" to .190"	2" 6"

- Tolerance for machining of electrode diameter "d" is ±.015" of specified dimension.
- Electrode force does not provide for force to press ill-fitting parts together.

APPLICATION DATA SHEET

NSRW Co., Inc. (800) 933-6779, FAX: (205) 663-3221 Authorized Distributor CMW Inc.



PROJECTION WELDING DATA

DESIGN AND WELDING DATA FOR PROJECTION WELDING LOW CARBON STEELS

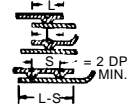
Thickness of Thinnest Outside Piece Inches	PROJECTION DESIGN		ELECTRODE DIAMETERS (d=2x Projection Diameter)		Electrode Force Pounds	Weld Time (Cycles) 60 Cycles per Sec.	Hold Time (Cycles) Minimum	Welding Current Amperes (Approx.)	Diameter of Fused Zone  Dw Inches	Minimum Shear Strength (Single Projection Only) (For Steels Having Strength of 100,000 psi and below) Pounds	Minimum Contacting Overlap  L Inches
	Base Diameter of Projection Dp Inches	Height of Projection H Inches	Minimum d Inches	Minimum D Inches							
0.010	0.055	0.015	0.125	1/2	50	3	3	2,800	0.112	150	1/8
0.012	0.055	0.015	0.125	1/2	80	3	3	3,100	0.112	200	1/8
0.014	0.055	0.015	0.125	1/2	100	3	3	3,400	0.112	250	1/8
0.016	0.067	0.017	0.187	1/2	115	4	4	3,600	0.112	285	5/32
0.021	0.067	0.017	0.187	1/2	150	6	6	4,000	0.140	380	5/32
0.025	0.081	0.020	0.187	1/2	200	6	8	4,500	0.140	525	3/16
0.031	0.094	0.022	0.187	1/2	300	8	8	5,100	0.169	740	7/32
0.034	0.094	0.022	0.187	1/2	350	10	10	5,400	0.169	900	7/32
0.044	0.119	0.028	0.250	5/8	480	13	14	6,500	0.169	1,080	9/32
0.050	0.119	0.028	0.250	5/8	580	16	16	7,100	0.225	1,500	9/32
0.062	0.156	0.035	0.312	7/8	750	21	20	8,400	0.225	2,100	3/8
0.070	0.156	0.035	0.312	7/8	900	24	24	9,200	0.281	2,550	3/8
0.078	0.187	0.041	0.375	7/8	1,050	26	30	10,500	0.281	2,950	7/16
0.094	0.218	0.048	0.500	7/8	1,300	32	30	11,800	0.281	3,700	1/2
0.109	0.250	0.054	0.500	7/8	1,650	38	36	13,300	0.338	4,500	5/8
0.125	0.281	0.060	0.500	7/8	1,800	45	40	15,000	0.338	5,200	11/16
0.140	0.312	0.066	0.625	1	2,300	60	45	15,700	0.437	6,000	3/4
0.156	0.343	0.072	0.625	1	2,800	80	50	17,250	0.500	7,500	13/16
0.171	0.375	0.078	0.750	1	3,300	105	50	18,600	0.562	8,500	7/8
0.187	0.406	0.085	0.750	1	3,800	125	50	20,000	0.562	10,000	15/16
0.203	0.437	0.091	0.875	1 1/4	4,500	145	55	21,500	0.625	12,000	1
0.250	0.531	0.110	1.000	1 1/4	6,600	230	60	26,000	0.687	15,000	1 1/4

NOTES:

- Type of Steel—Low Carbon SAE 1010—0.15% Carbon Maximum.
- Material free of scale, oxide, paint, dirt, etc.
- Size of projection determined by thickness of thinnest piece and projection should be on thickest piece.
- Data is based on thickness of thinnest sheet for two thicknesses only. Maximum ratio between two thicknesses = 3 to 1.
- See TABLE BELOW for design of punch and die for making projections.
- Contacting overlap does not include any radii from forming.
- Projection should be located in center of overlap.

8. Tolerance for Projection Dimensions:

Dimension	Thickness Up to 0.050"	Thickness Over 0.050"
Diameter "D"	±0.003"	±0.007"
Height "H"	±0.002"	±0.005"

9. Electrode Material:

CMW® 100 ELKONITE®TC-10 ELKONITE®10W3

From American Welding Society "Recommended Practices for Resistance Welding"

PUNCH AND DIE DESIGN FOR FORMING WELDING PROJECTIONS

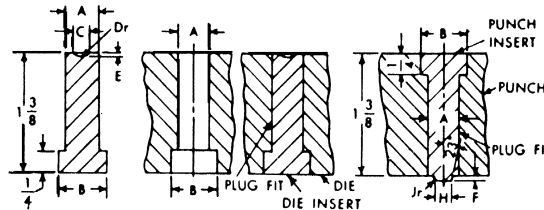

Mat Thickness	Pt. No.	A	B	±.002 C	Dr	±.001 E	±.001 F	±.001 H	Jr
0.010-0.015	1	3/8	9/16	.055	.033	.015	.015	.035	.005
0.016-0.021	2	3/8	9/16	.067	.042	.017	.020	.039	.005
.025	3	3/8	9/16	.081	.050	.020	.025	.044	.005
.031	4	3/8	9/16	.094	.062	.022	.030	.050	.005
.034	5	3/8	9/16	.094	.062	.022	.030	.050	.005
.044	6	3/8	9/16	.119	.078	.028	.035	.062	.005
.050	7	3/8	9/16	.119	.078	.028	.035	.062	.005
.062	8	3/8	9/16	.156	.105	.035	.043	.081	.005
.070	9	3/8	9/16	.156	.105	.035	.043	.081	.005
.078	10	3/8	9/16	.187	.128	.041	.055	.104	.010

Mat Thickness	Pt. No.	A	B	±.002 C	Dr	±.001 E	±.001 F	±.001 H	Jr
.094	11	1/2	11/16	.218	.148	.048	.065	.115	.010
.109	12	1/2	11/16	.250	.172	.054	.075	.137	1/64
.125	13	1/2	11/16	.281	.193	.060	.085	.154	1/64
.140	14	1/2	11/16	.312	.217	.066	.096	.172	1/64
.156	15	5/8	13/16	.343	.243	.072	.107	.191	1/64
.171	16	5/8	13/16	.375	.265	.078	.118	.210	1/64
.187	17	5/8	13/16	.406	.285	.085	.130	.229	1/64
.203	18	11/16	7/8	.437	.308	.091	.143	.240	.020
.250	19	13/16	1	.531	.375	.110	.175	.285	.025

Material: Tool Steel. Finish all over and harden to 65-68 Rockwell "C" scale. Note: All working surfaces of die unit must be polished.

From American Welding Society "Recommended Practices for Resistance Welding"

APPLICATION DATA SHEET

NSRW Co., Inc. (800) 933-6779, FAX: (205) 663-3221 Authorized Distributor CMW Inc.



SCHEDULE FOR SPOT WELDING STAINLESS STEEL

THICKNESS "T" OF THINNEST OUTSIDE PIECE (See Notes 1, 2, 3 and 4 Below)	ELECTRODE DIAMETER AND SHAPE (See Note 5)		ELECTRODE FORCE LB.	WELD TIME CYCLES (60 Per Sec.)	WELDING CURRENT (Approx.) AMPS		MINIMUM CONTACTING OVERLAP 	MINIMUM WELD SPACING (See Note 6 Below) ϕ to ϕ	DIAMETER OF FUSED ZONE 	MINIMUM SHEAR STRENGTH LB.		
	D, IN., Min.	d, IN., Max.			Tensile Strength Below 150000 Psi	Tensile Strength 150000 Psi and Higher				Ultimate Tensile Strength of Metal		
										70000 Up to 90000 Psi	90000 Up to 150000 Psi	150000 Psi and Higher
0.006	3/16	3/32	180	2	2000	2000	3/16	3/16	0.045	60	70	85
0.008	3/16	3/32	200	3	2000	2000	3/16	3/16	0.065	150	170	210
0.012	1/4	1/8	260	3	2100	2000	1/4	1/4	0.076	185	210	250
0.014	1/4	1/8	300	4	2500	2200	1/4	1/4	0.082	240	250	320
0.016	1/4	1/8	330	4	3000	2500	1/4	5/16	0.088	280	300	380
0.018	1/4	1/8	380	4	3500	2800	1/4	5/16	0.093	320	360	470
0.021	1/4	5/32	400	4	4000	3200	5/16	5/16	0.100	370	470	500
0.025	3/8	5/32	520	5	5000	4100	3/8	7/16	0.120	500	600	680
0.031	3/8	3/16	650	5	6000	4800	3/8	1/2	0.130	680	800	930
0.034	3/8	3/16	750	6	7000	5500	7/16	9/16	0.150	800	920	1100
0.040	3/8	3/16	900	6	7800	6300	7/16	5/8	0.160	1000	1270	1400
0.044	3/8	3/16	1000	8	8700	7000	7/16	11/16	0.180	1200	1450	1700
0.050	1/2	1/4	1200	8	9500	7500	1/2	3/4	0.190	1450	1700	2000
0.056	1/2	1/4	1350	10	10300	8300	9/16	7/8	0.210	1700	2000	2450
0.062	1/2	1/4	1500	10	11000	9000	5/8	1	0.220	1950	22400	2900
0.070	5/8	1/4	1700	12	12300	10000	5/8	1 1/8	0.250	2400	2800	3550
0.078	5/8	5/16	1900	14	14000	11000	11/16	1 1/4	0.275	2700	3400	4000
0.094	5/8	5/16	2400	16	15700	12700	3/4	1 1/2	0.290	3550	4200	5300
0.109	3/4	3/8	2800	18	17700	14000	13/16	1 1/2	0.290	4200	5000	6400
0.125	3/4	3/8	3300	20	18000	15500	7/8	2	0.300	5000	6000	7600

NOTES:

- Types of Steel—301, 302, 303, 304, 308, 309, 310, 316, 317, 321, 347 and 349
- Material should be free from scale, oxides, paint, grease and oil.
- Welding conditions determined by thickness of thinnest outside piece "T."
- Data for total thickness of pile-up not exceeding 4 "T". Maximum ratio between two thicknesses 3 to 1.

- Electrode Material, CMW® 3, CMW® 100, or ELKONITE® 10W3
- Minimum weld spacing is that spacing for two pieces for which no special precautions need be taken to compensate for shunted current effect of adjacent welds. For three pieces increase spacing 30 per cent.

SCHEDULE FOR SEAM WELDING STAINLESS STEEL

THICKNESS "T" OF THINNEST OUTSIDE PIECE (See Notes 1, 2, 3 and 4 Below)	ELECTRODE WIDTH AND SHAPE (See Note 5 Below) 	ELECTRODE FORCE LB.	ON TIME CYCLES (60 Per Sec.)	OFF TIME FOR MAXIMUM SPEED (Pressure-Tight) CYCLES		MAXIMUM WELD SPEED IN. PER MINUTE		WELDS PER INCH		WELDING CURRENT (Approx.) AMPS.	MINIMUM CONTACTING OVERLAP (See Note 6 Below) 			
				W, IN., Min.	2 "T"	4 "T"	2 "T"	4 "T"	2 "T"			4 "T"		
													2 "T"	4 "T"
0.006	3/16	300	2	1	1	60	67	20	18	4000	1/4			
0.008	3/16	350	2	2	2	67	56	18	16	4600	1/4			
0.010	3/16	400	3	2	2	45	51	16	14	5000	1/4			
0.012	1/4	450	3	2	2	48	55	15	13	5600	5/16			
0.014	1/4	500	3	2	3	51	46	14	13	6200	5/16			
0.016	1/4	600	3	2	3	51	50	14	12	6700	5/16			
0.018	1/4	650	3	2	3	55	50	13	12	7300	5/16			
0.021	1/4	700	3	2	3	55	55	13	11	7900	3/8			
0.025	3/8	850	3	3	4	50	47	12	11	9200	7/16			
0.031	3/8	1000	3	3	4	50	47	12	11	10600	7/16			
0.040	3/8	1300	3	4	5	47	45	11	10	13000	1/2			
0.050	1/2	1600	4	4	5	45	44	10	9	14200	5/8			
0.062	1/2	1850	4	5	7	40	41	10	8	15100	5/8			
0.070	5/8	2150	4	5	7	44	41	9	8	15900	11/16			
0.078	5/8	2300	4	6	7	40	41	9	8	16500	11/16			
0.094	5/8	2550	5	6	7	36	38	9	8	16600	3/4			
0.109	3/4	2950	5	7	9	38	37	8	7	16800	13/16			
0.125	3/4	3300	6	6	8	38	37	8	7	17000	7/8			

NOTES:

- Types of Steel—301, 302, 303, 304, 308, 309, 310, 316, 317, 321, 347 and 349
- Material should be free from scale, oxides, paint, grease and oil.
- Welding conditions determined by thickness of thinnest outside piece "T."
- Data for total thickness of pile-up not exceeding 4 "T". Maximum ratio between two thicknesses 3 to 1.

- Electrode material, CMW® 100
- For large assemblies minimum contacting overlap indicated should be increased 30 per cent.

From American Welding Society "Recommended Practices for Resistance Welding"

APPLICATION DATA SHEET

NSRW Co., Inc. (800) 933-6779, FAX: (205) 663-3221 Authorized Distributor CMW Inc.



Spot welding galvanized low-carbon steel

Material Thickness	Electrode Diameter And Shape			Net Electrode Force	Welding Current (Approx.)	Weld Time	Weld Nugget Size	Minimum Tension-Shear Strength	Minimum Weld Spacing	Minimum Contacting Overlap
	D	d	Oc							
notes 1, 2, & 3	note 4 									
Inches	In.	In.	Deg.	Lb.	Amps.	Cycles	In.	Lb.	Inches	Inches
0.022	5/8	3/16	120	300	13000	8	0.15	550	5/8	5/8
0.030	5/8	3/16	120	400	13000	10	0.16	1000	5/8	5/8
0.036	5/8	1/4	120	500	13500	12	0.19	1180	3/4	5/8
0.039	5/8	1/4	120	650	14000	13	0.21	1400	3/4	5/8
0.052	5/8	1/4	120	725	14500	18	0.22	1700	7/8	11/16
0.063	3/4	1/4	120	850	15500	22	0.24	2500	1-1/8	3/4
0.078	3/4	5/16	120	1200	19000	24	0.28	3200	1-1/4	7/8
0.093	3/4	3/8	120	1400	21000	30	0.34	4200	1-1/2	1
0.108	7/8	3/8	120	1750	20000	37	0.40	5900	1-3/4	1-1/8
0.123	7/8	3/8	120	2000	20000	42	0.48	7200	2	1-1/8

NOTES:

1. Material must be free from dirt, grease, paint etc. prior to welding, but may have light oil.
2. Two equal metal thicknesses of each gage.
3. Commercial coating weight is 1.25 oz. per square foot.
4. Electrode Material-RWMA Group A, Class 2. CMW®3.
5. Water Cooling: 2 gallons per minute.

Projections should be larger in diameter for galvanized than for uncoated material.

Projection welding galvanized low-carbon steel

Material Thickness	Electrode Diameter And Shape		Net Electrode Force	Welding Current (Approx.)	Weld Time	Weld Nugget Size	Minimum Tension-Shear Strength	Projection Size	
	D	d						Diameter	Height
notes 1, 2, & 3	note 4 						(For Single Projections Only)		
Inches	In.	In.	Lb.	Amps.	Cycles	In.	Lb.	In.	In.
0.039	5/8	3/8	250	10000	15	0.15	925	0.187	0.041
0.063	5/8	7/16	400	11500	20	0.25	2050	0.218	0.048
0.078	3/4	1/2	550	16000	25	0.25	2700	0.250	0.054
0.093	3/4	1/2	750	16000	30	0.30	4300	0.250	0.054
0.108	7/8	1/2	950	22000	33	0.31	4900	0.250	0.054

NOTES:

1. Material must be free from dirt, grease, paint etc. prior to welding, but may have light oil.
2. Two equal metal thicknesses of each gage.
3. Commercial coating weight is 1.25 oz. per square foot.
4. Electrode Material-RWMA Group A, Class 2. CMW®3.
5. Pressure-tight joints require stripping the zinc coating prior to welding.
6. Nominal electrode diameter ranges between 8 to 10 inches.

From American Welding Society "Recommended Practices for Resistance Welding."

Seam welding galvanized low-carbon steel

Material Thickness	Electrode Width And Shape		Net Electrode Force	Welding Current (Approx.)	Weld Time		Welding Speed	Welds Per Inch	Minimum Contacting Overlap
	W	E			Heat Time	Cool Time			
notes 1, 2, & 3	note 4 								
Inches	In.	In.	Lb.	Amps.	Cycles	Cycles	In./Min.	W/In.	Inches
0.015	3/8	1/4	900	15000	2	2	120	7.5	3/8
0.036	1/2	1/4	1100	18000	4	2	60	10.0	1/2
0.039	1/2	1/4	1200	19000	4	3	60	9.0	1/2
0.052	1/2	1/4	1350	20000	5	1	90	7.0	9/16
0.063	1/2	5/16	1500	19800	8	2	54	7.0	5/8
0.078	5/8	5/16	1850	23000	10	7	30	7.0	11/16

DATA SHEET



NSRW Co., Inc. (800) 933-6779, FAX: (205) 663-3221 Authorized Distributor CMW Inc.

RECOMMENDED ELECTRODE MATERIALS

The process of resistance welding makes it possible to join most metals, similar or dissimilar. Bonds of adequate strength are obtainable for an extremely wide range of applications. Selecting electrodes of the proper alloy is a most important consideration in producing good welds at the required speed. The chart below is a valuable guide to this selection.

The weldability of two materials as expressed in the following chart has been derived after careful laboratory study and field survey of many factors which influence the welding or resultant weld of the metals. The factors include:

1. Thermal and electrical conductivity

2. Metallurgical properties
3. Nature of resultant weld or alloy
4. Weld strength
5. Relative accuracy in control of welding conditions necessary

The weldability of metals as shown in the chart applies only when conventional spot welding methods are used on similar thicknesses of material. However, many metal combinations which are listed as having a "poor weldability" may be satisfactorily joined by using a special setup or procedure.

There is a CMW® Alloy for each specific welding application. Experienced CMW engineers will provide assistance with special problems.

Electrode Materials For SPOT WELDING Similar and Dissimilar Metals

	Tungsten Molybdenum	Magnesium	Nickel Alloys	Nickel	Stainless Steel	Chrome Steel	Cadmium Plate	Galvanized Steel Zinc Plate	Terne Plate	Tin Plate	Scaly Steel	C.R. Steel	Phosphor Bronze	Silicon Bronze	Nickel Silver	Cupro Nickel	Brass Yellow	Brass Red	Copper	Aluminum Alloys	Aluminum	C.P. Titanium	
Commercially Pure Titanium																							A 1
Aluminum 2S-3S			C I E I I I E I I H I H I I E I D I D I D I																				
Aluminum Alloys Duralumin 52S-17S-24S			C I E I I I E I I H I H I I E I D I D I D I																				
Copper—Pure			H I I H I E I I E I I H I H I I H I H I H I																				
Brass—Red 5-25%Zinc			H I D I I D I I H I H I I H I H I H I																				
Brass—Yellow 25-40%Zinc			E I D I I D I I H I H I I E I E I E I																				
Cupro-Nickel			D I C I I C V I E I E I E I E I H I E I C I I C I I C I I B I I																				
Nickel Silver			D I C I I C V I E I E I E I E I H I E I C I I C I I B I I																				
Silicon Bronze			D I C I I D I I E I E I E I E I H I D I I C I I B I I																				
Phosphor Bronze Grades A, C, & D			E I D I I D I I E I E I E I E I H I D I I B I I																				
C.R. Steel H.R. Steel—Clean			D I I D I I D I I B I I B I I C I I C I B I C I E I A I I																				
Scaly H.R. Steel			H I I D I I D I I D I I D I I D I I D I E I E I																				
Tin Plate			E I I E I D I I D I I C I I C I I D I C I D I D I																				
Terne Plate			E I I E I D I I D I I C I I C I I C I C I C I																				
Galvanized Steel Zinc Plate			E I I E I D I I D I I C I I C I I C I C I C I																				
Cadmium Plate			E I I E I D I I D I I C I I C I I C I																				
Chrome Plate			D I I D I I D I I B I I B I I																				
Stainless Steel 18-8 Type			D I I D I I D I I A I I																				
Nickel Grade A			D I I C I I B I I																				
Nickel Alloys Monel Nichrome (High Res.)			D I I B I I																				
Magnesium Alloys			D I I																				
Molybdenum Tungsten			D I I																				

BLOCK INTERPRETATION

WELD-ABILITY	ELECTRODE AGAINST
ELECTRODE AGAINST	SPECIAL INFORMATION

WELDABILITY

As a basis for comparison cold rolled (mild) steel has been chosen and its weldability designated as "excellent."

- A—Excellent
- B—Very Good
- C—Good
- D—Fair
- E—Poor
- H—Very Poor
- K—Impractical

ELECTRODES

- I—CMW 28
- II—CMW 3
- III—CMW 100
- IV—ELKONITE® 10W3
- V—ELKONITE® 100M*
- VI—ELKONITE® 1W3 or TC-5

*ELKONITE® 100 W may be substituted. ELKONITE® 10W3 or TC-10 may be interchanged. Electrode materials in circles are second choice.

SPECIAL INFORMATION

1. Good weld strength.
2. May be welded under special conditions.
3. Low weld strength.
4. No actual weld nugget occurs, a "stick" is obtained.
5. Welding conditions must be accurately controlled.
6. Keep electrode clean to prevent sticking to the work.
7. Good practice recommends cleaning steel before welding.
8. Use one flat tip to minimize distortion or discoloration.
9. Coating may dissolve in other metals or burn away.

RESISTANCE WELDING ELECTRODE MAINTENANCE

NSRW Co., Inc. (800) 933-6779, FAX: (205) 663-3221 Authorized Distributor CMW Inc.



This Chart shows graphically the importance of Electrode maintenance. This is not only important from the quality of the weld, which is of first importance, also extra load added to the welding machine and equipment. Read the data on the chart, you can then draw your own conclusions.

YOU CAN'T AFFORD TO NEGLECT YOUR ELECTRODES !

Keep your Electrodes dressed for maximum production and quality welds.

A TIP DRESSER WILL PAY DIVIDENDS !

We can supply you with hand operated Tip Dressers or Pneumatic Power Driven Dressers. Design or type will depend on your production requirements. P. 46 & 47.

RESISTANCE WELDING

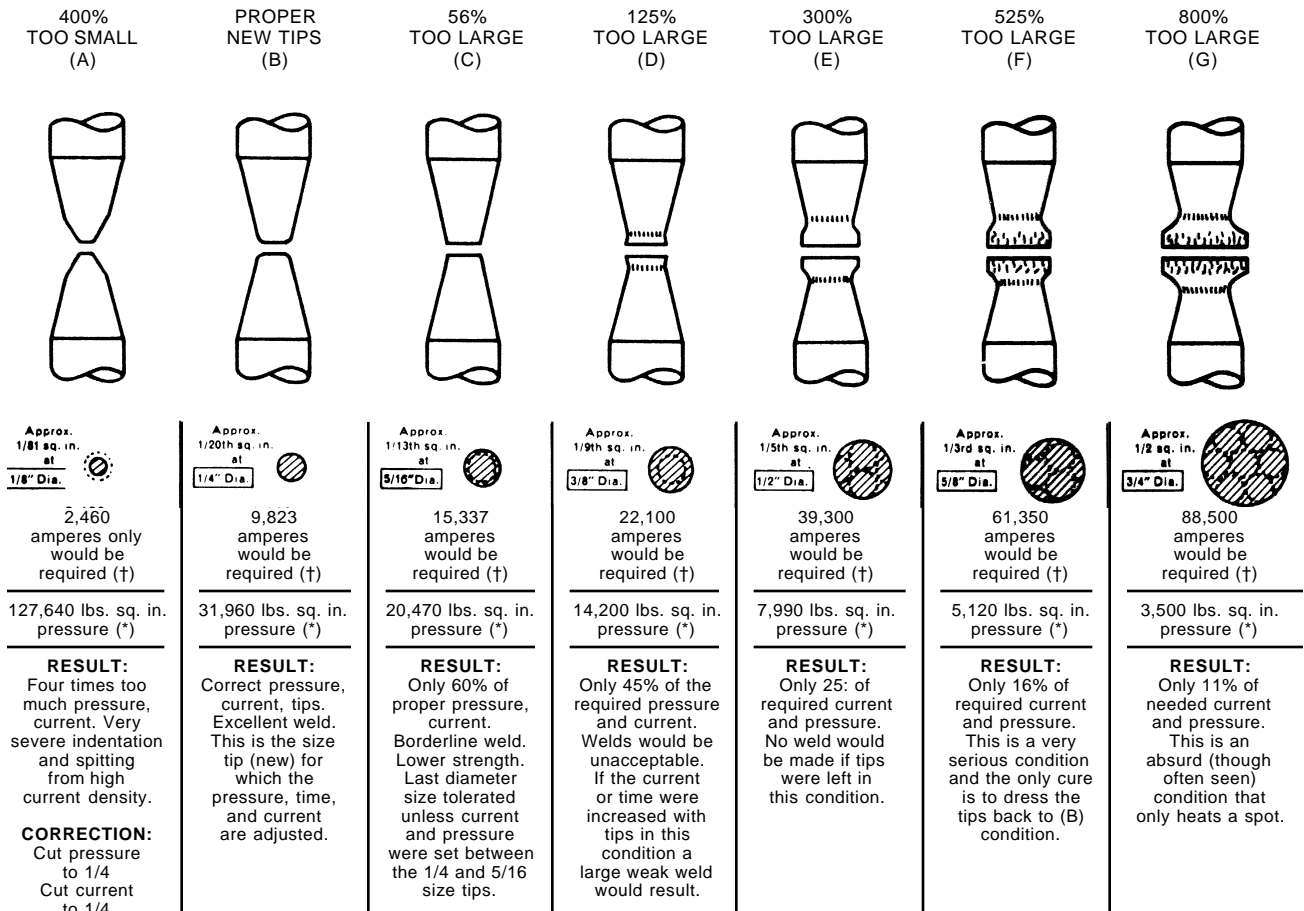

(†) Current density required for this gage to be 200,000 amps per sq. in. Setting is 9,900 amps for condition (B)

(*) Five inch diameter air cylinder A 80 lbs. air pressure—1570 lbs. on ram.

Reproduced by permission of McGraw-Hill Book Company, Inc.

WELDING ELECTRODE/CAP EVALUATION FORM



NSRW Co., Inc. (800) 933-6779, FAX: (205) 663-3221 Authorized Distributor CMW Inc.

Facility _____

Location _____

Contact _____ Phone _____ Fax _____ Date _____

Equipment --- Plant/Line # _____							
TYPE	Robot	Fixed Auto	Press	Hand	Online	Offline	Other (Specify)
GUN STYLE	C Gun	Pinch	Scissor	Other (Specify)	Comment		
CONDITION	New	Old	Good	Poor			
STEPPER CAPABILITY	Number of Steps	Linear	Non-linear	None			
UP-SLOPE CAPABILITY	Yes	No					
PULSE CAPABILITY	Yes	No					
NUMBER OF	Schedules per SCR	Transformers per SCR	Guns per Transformer	Transformer Taps	Transformer KVA		

Workpieces (Materials)							
POSITION	THICKNESS	CHECK ONE (per workpiece)					
		Bare Steel	Aluminized	Zn Electroplate	Galvanneal	Hod Dipped Galvanized	Organic
Outside							
Inside							
Inside							
Outside							
FIT-UP	Good	Poor	Comments				

ELECTRODES							
NOSE STYLE	A (pointed)	B (Dome)	C (Flat)	D (Offset)	E (Truncated)	F (Radius)	Other (specify)
MATERIAL	Class 1	Class 2	Class 20 (DSC)	Other (Specify)			
TAPER STYLE	Female	Male		Comments			
ALIGNMENT	Good	Poor	Requires Backup				



NSRW Co., Inc. (800) 933-6779, FAX: (205) 663-3221 Authorized Distributor CMW Inc.

Resistance Welding Electrodes and Holders

DO'S	DON'TS
<ol style="list-style-type: none"> 1. Use the proper electrode material for the job you are doing. 2. Use standard electrodes wherever possible. 3. Use the most suitable tip diameter for the thickness of stock being welded. 4. Use open sight drains to observe more readily the water flow through the holders. 5. Connect the water inlet hose to the proper holder inlet so that the water flows through the center cooling tube first. 6. Internally cool the spot welding tips with cool water flowing at a rate of at least 1/2 gallons per minute through each tip. 7. Be sure the internal water cooling tube of the holder projects into the tip water hole to within 1/4" of the tip hole bottom. 8. Adjust the internal water cooling tube of the holder to the proper height when changing to a different length tip. 9. Be sure top of adjustable water cooling tube in holders is cut at an angle so as to avoid jamming tip down and shutting water off. 10. Place a thin film of cup grease on the tip taper prior to inserting in the holder, to make it easier to remove. 11. Use ejector type holders for easy removal of tips and to avoid damage to tip tapers. 12. Keep the tip taper and holder taper clean, smooth and free of foreign deposits. 13. Dress spot welding electrodes frequently enough to maintain the quality of the welds. 14. Dress electrodes in a lathe to their original contour whenever possible. 15. Use a rawhide or rubber mallet for striking holder or tips in aligning operations. 16. Provide flood cooling on both sides of the seam welding wheel. 17. Use properly designed knurling wheels to maintain proper seam welding wheel shape. 	<ol style="list-style-type: none"> 1. Never use unidentified electrodes or electrode materials. 2. Avoid special, offset or irregular tips when the job can be done with a standard straight tip. 3. Don't use small tips on heavy gauge welding jobs or large tips on small work. 4. Don't forget to turn on the cooling water full force before starting to weld. 5. Never use water hose that will not fit the holder water connection nipples snugly. 6. Do not allow water connections to become leaky, clogged or broken. 7. Avoid using holders with leaking or deformed tapers. 8. Never use electrode holders that do not have an adjustable internal water cooling tube. 9. Do not permit adjustable water tube to be "frozen" by accumulation of deposits. A few drops of oil periodically will keep the tube free. 10. Do not allow electrodes to remain idle in tapered holder seats for extended periods. 11. Don't use pipe wrenches or similar tools in removing electrodes. 12. Avoid using white lead or similar compounds to seal a leaking taper. 13. Never permit a spot welding tip to mushroom enough to make dressing difficult. 14. Never dress electrodes with a coarse file. 15. Don't pound on the holder or tip with a steel hammer in aligning the welder arms. 16. Avoid the use of seam welder wheels too thin to stand the heat or pressure of your job. 17. Do not permit seam welding wheel to run off the corners of the work being welded.